

[www.nomurads.com](http://www.nomurads.com)

English

Auto lathe maker with 70 years of tradition

# NOMURADS

## Swiss Type CNC Automatic Lathe Series



# NOMURADS

## History

70 year's tradition for high quality  
CNC Automatic Lathes

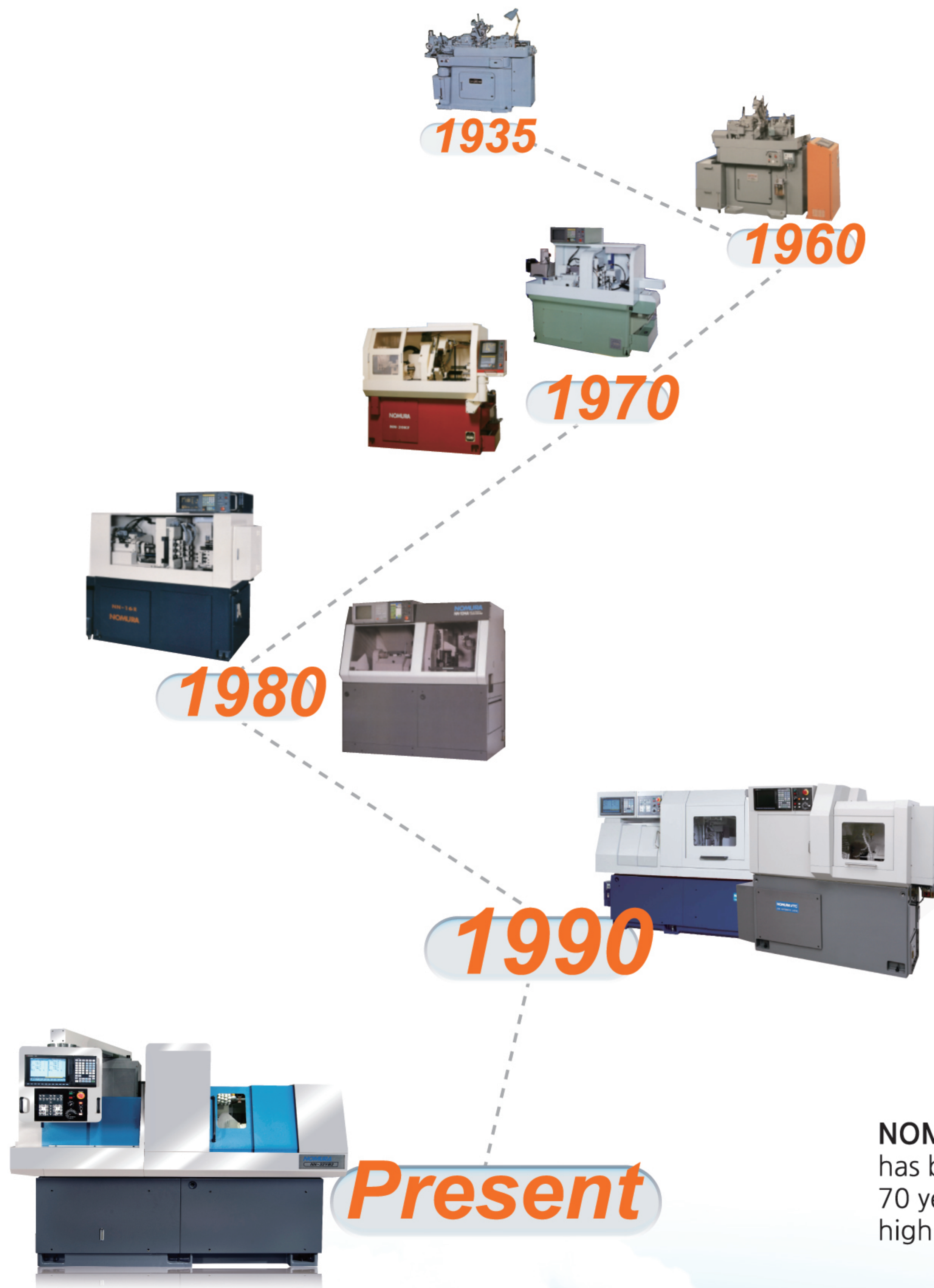

**1935** - Lathe research started  
(Founder: Mr. Koji Nomura)  
- Established NOMURA

**1960** - 4,000 sets of cam-type lathe sold  
- NS1530, 8410 sales started in 1945

**1970** - Developed IC 10A  
- Export started from 1964  
- Started sales of NC cam lathe

**1980** - Developed CNC M-LO 160V  
- Developed CNC M-300 KF  
- Developed CNC M-500 16R, U2

**1990** - Established  
NOMURA Auto Lathe Co., Ltd.  
- 15,000 sets of cam-type lathe sold

**Present** - 14,000 sets of CNC lathe sold  
- Developed 3X, 10EX2, 38UB8  
- Developed NOMURA Tapping Center  
- Developed Fanuc NC equipped lathe

**NOMURADS**  
has been manufacturing swiss type CNC auto lathe for the last  
70 years. When you choose NOMURADS, you will have  
high precision, durability and innovation for your production



# NOMURADS

## Global Business Network

- Headquarters
- Overseas Offices
- Overseas Partners

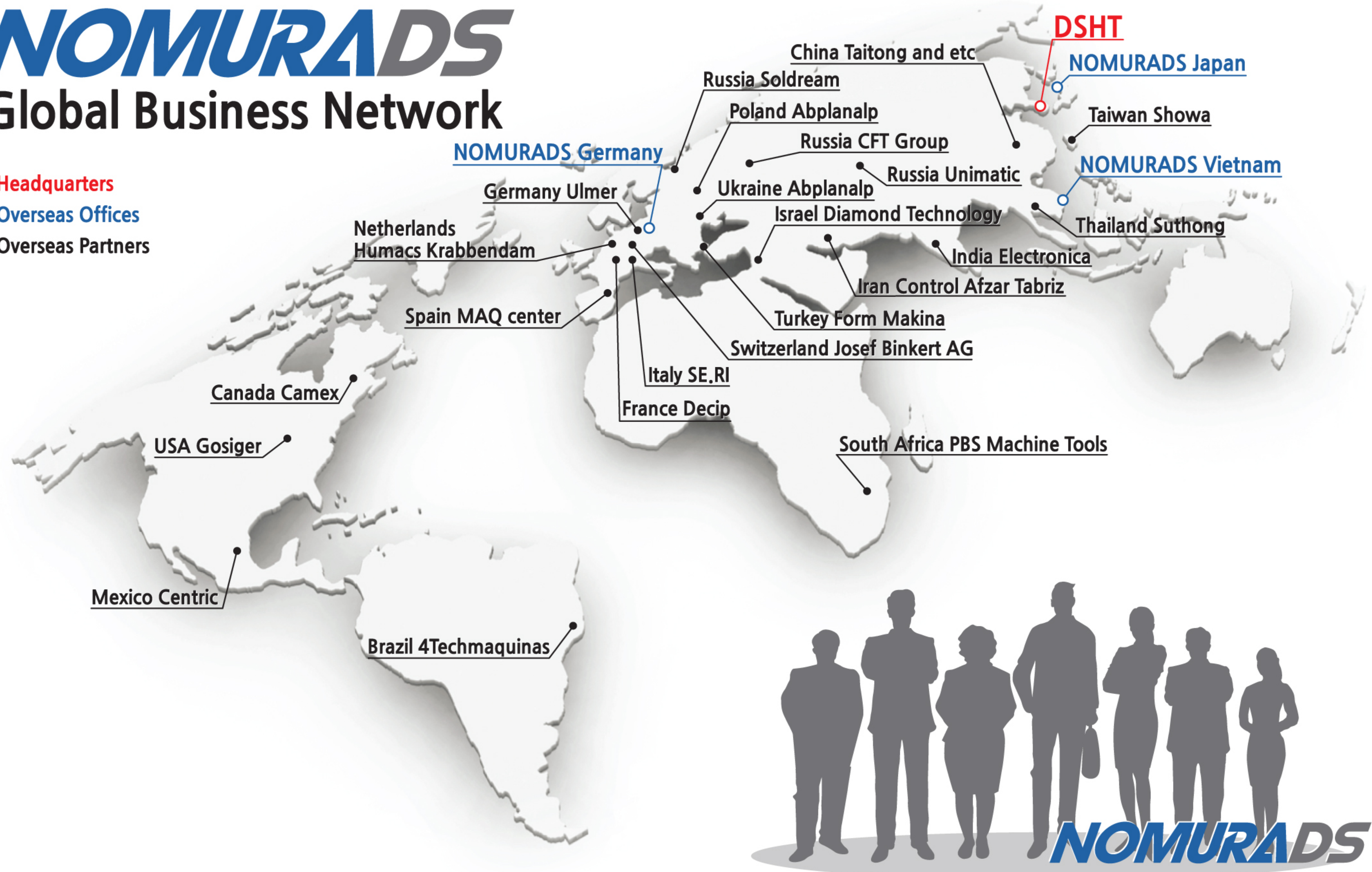

### NOMURADS

#### Dovetail structure

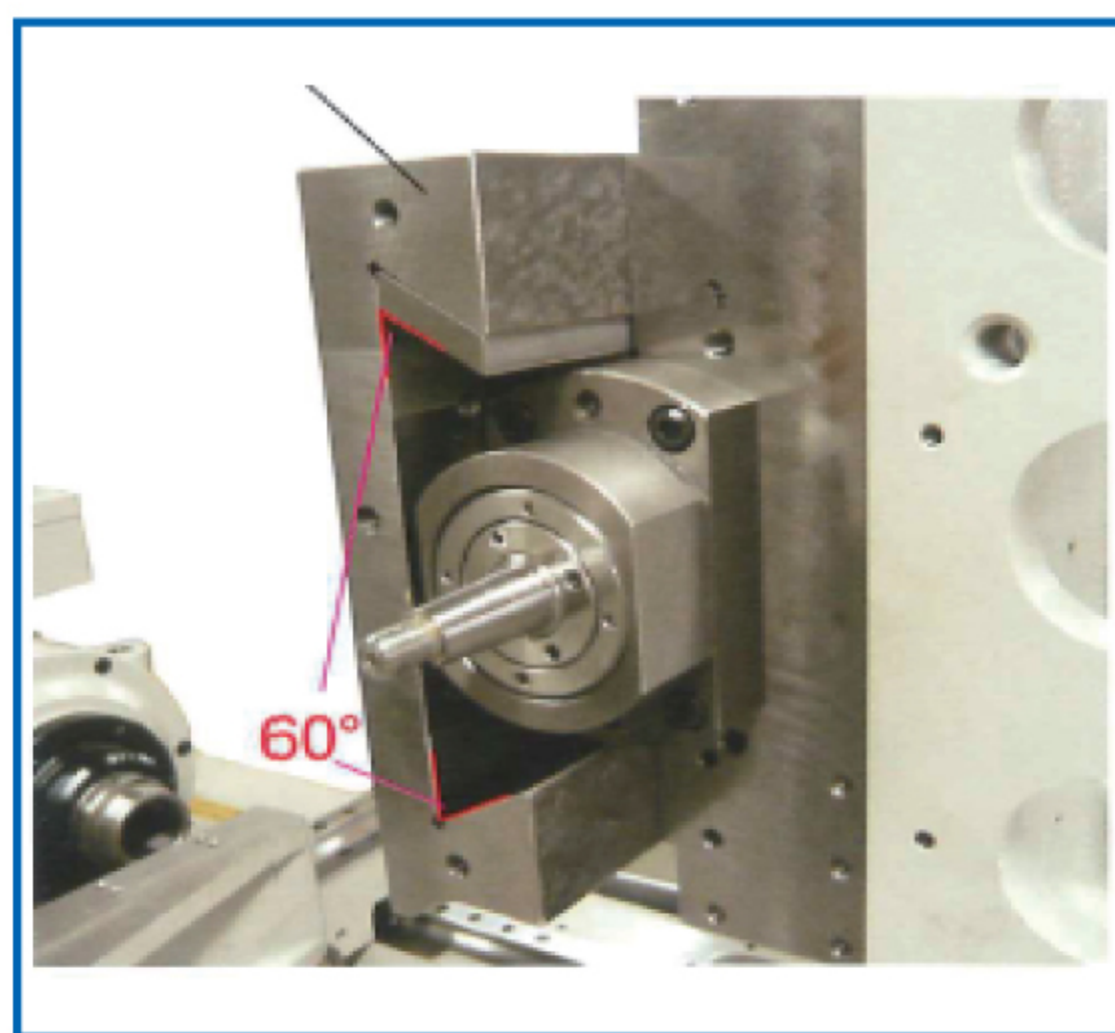

The rigidity of NOMURA DS machine is enhanced as its structure contacts the surface of both sides.

#### Hand scraping



The weighty tool post is glided smoothly by our master artisans and high precision is enhanced as the result.

#### Integrated casting bed



Machine vibrations is absorbed and machining tolerance affected by the temperature change of cutting oil can be minimized as temperature turning is enacted with coolant tank located in the casting bed.

### Tool presetter - Option

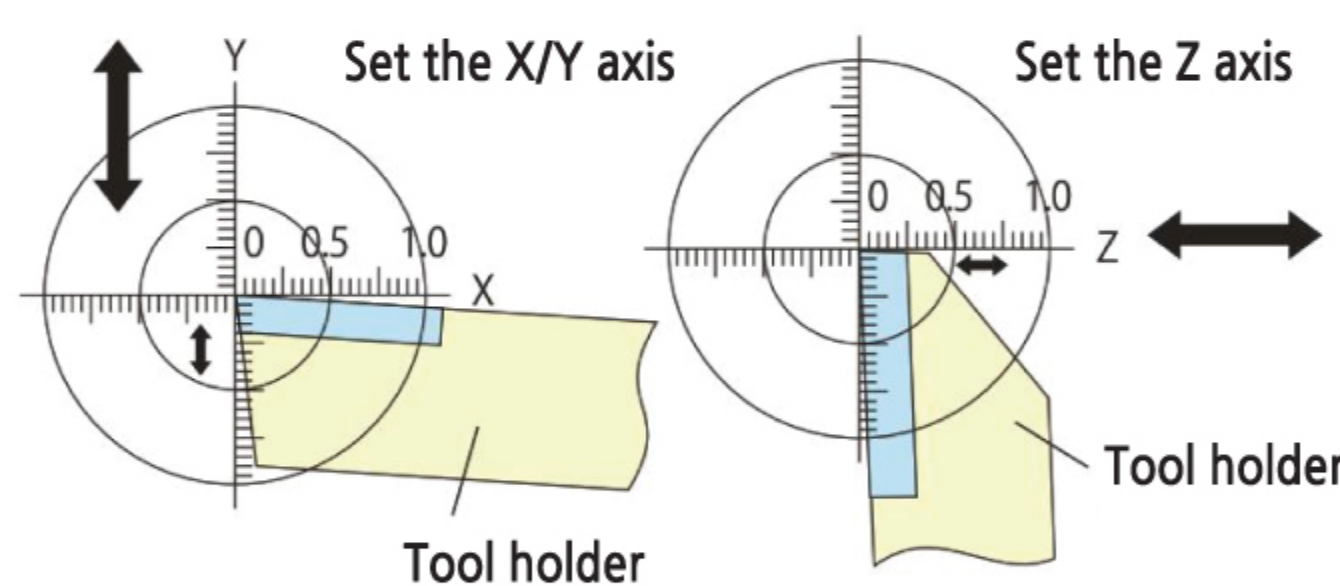
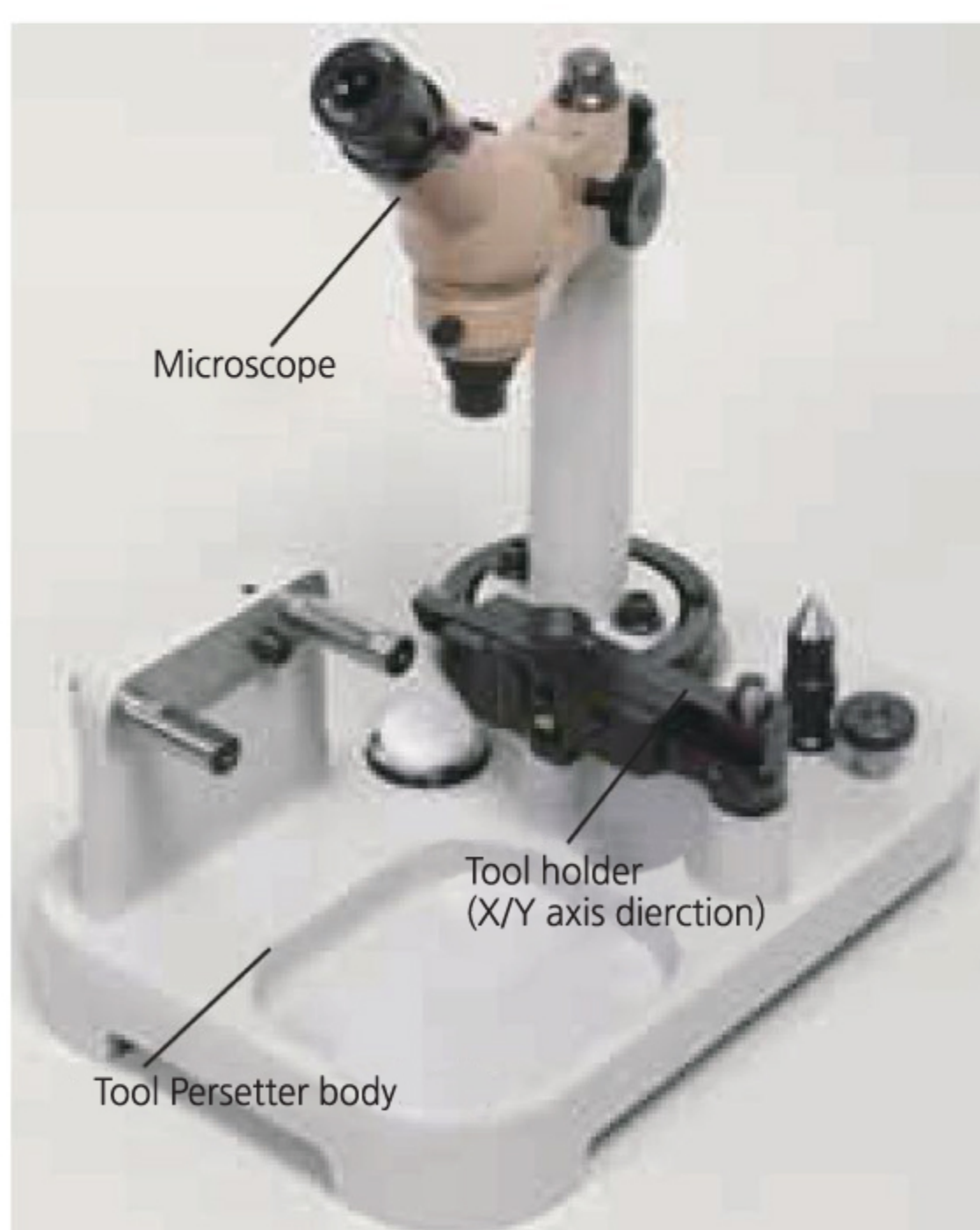

- Set the X/Y axis direction
- Set the Z axis direction. This is all you need to do.



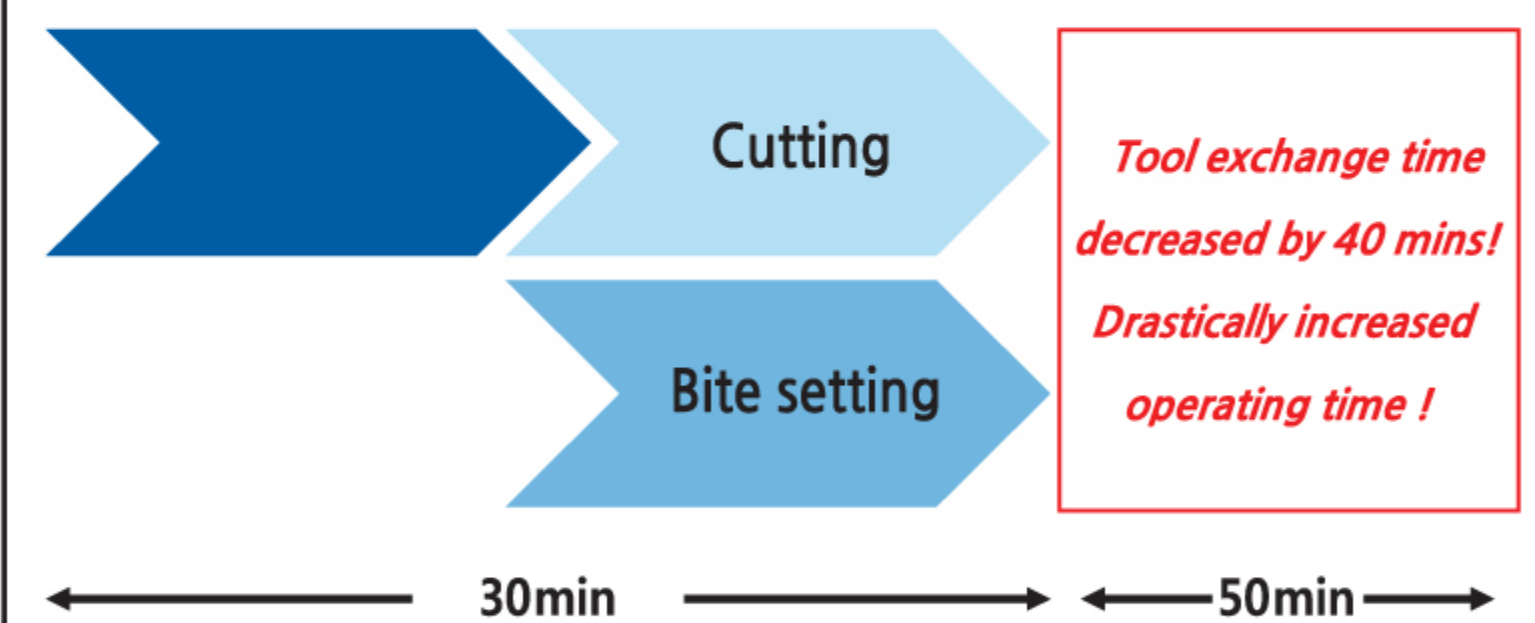



#### NOMURADS Tool Holder Type



#### Competitors' direct mounted (fixed bite) type

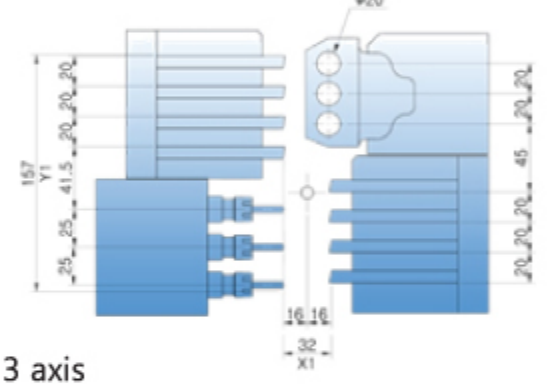
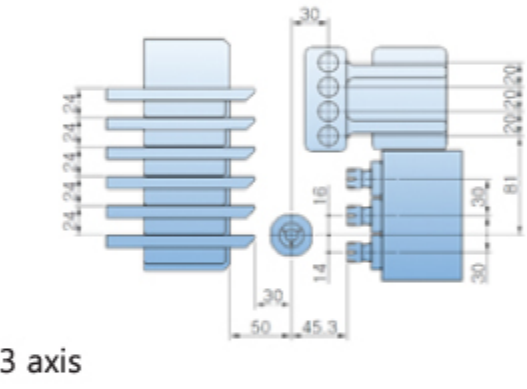
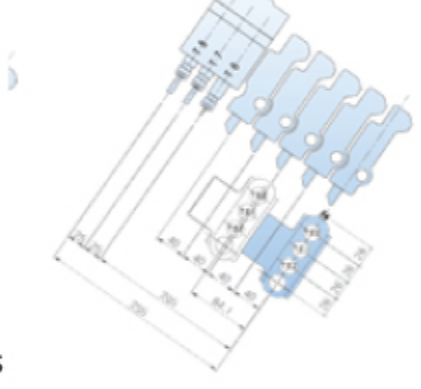
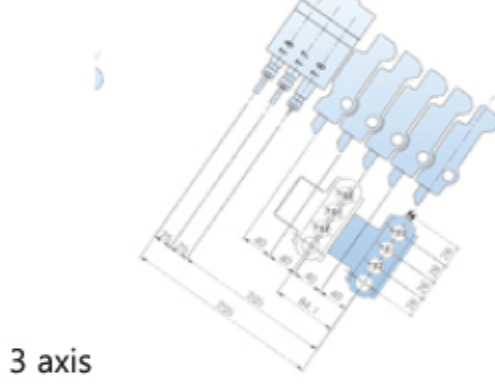
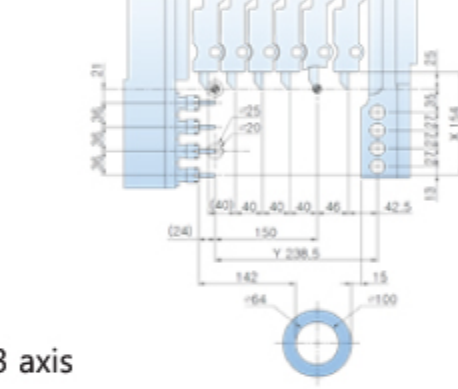
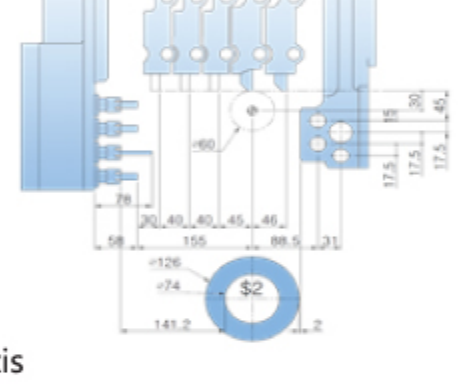
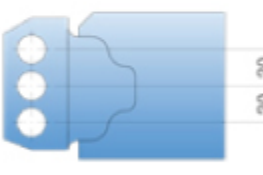
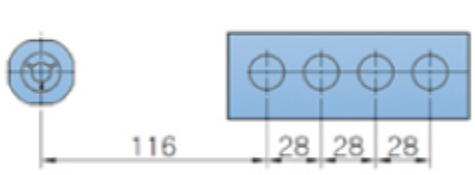
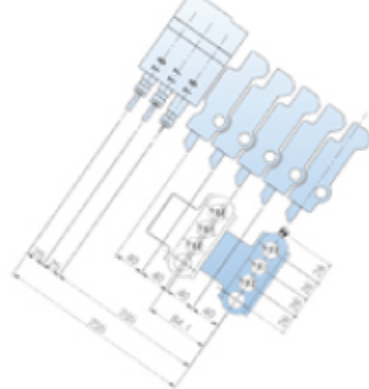
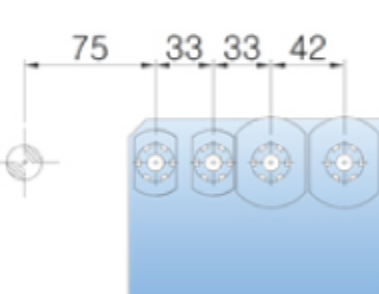
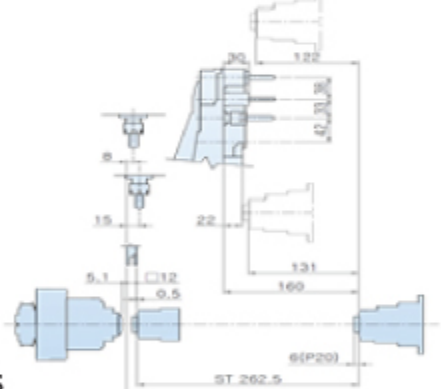

# PRODUCT LINE UP

Content	NAME	NN-3X	NN-10EX2	NN-165B6	NN-165B7	NN-20/25U5	NN-20/25UB8(K)	
	TYPE	S	S	S	S	S/N	S/N	
	NC	FANUC Oi-TF	Mitsubishi M80	Mitsubishi M70A	Mitsubishi M70V TypeA / FANUC Oi-TF	Mitsubishi M70	Mitsubishi M70V Type A / FANUC Oi-TF	
Specification	Photo							
	\$1 Tool Lay-out [MAIN]							
	\$2 TOOL LAY-OUT [SUB]					N/A		
	Max. Machining capacity (Ø)	Ø3	Ø10	Ø16	Ø16	Ø20 / Ø25	Ø20 / Ø25	
\$1	Max. rpm	20,000rpm	15,000rpm	10,000rpm	10,000rpm	10,000rpm	10,000rpm	
	Power	1.1/0.75kW	3.7/1.5kW	2.2/1.5kW	2.2/1.5kW	3.7/2.2kW	3.7/2.2kW	
\$2	Max. rpm	20,000rpm	15,000rpm	7,000rpm	7,000rpm	-	6,000rpm	
	Power	1.1/0.75kW	1.1/0.75kW	0.75/0.3kW	0.75/0.3kW	-	1.5/0.55kW	
Max. Number of tools		17 tools	22 tools	16 tools	20 tools	13 tools	21 tools	
\$1	O.D.	Number of tools	8 tools	6 tools	5 tools (Option: 7 tools)	5 tools	5 tools	5 tools
		Bite size	□8	□10	□12.7	□12.7	□12.7	□12.7
	I.D.	Number of tools	ER8×3 tools+3 tools	ER11×4 tools+4 tools	ER11×4 tools+4 tools(Option: ER16×3 tools+3 tools)	ER11×4 tools+4 tools(Option: ER16×3 tools+3 tools)	ER16×4 tools	ER16×4 tools+4 tools
		Max. rpm	9,000rpm	10,000rpm	8,000rpm	8,000rpm	6,000rpm	6,000rpm
	Cross	Power	0.35kW	0.4kW	0.4kW	0.4kW	0.75kW	0.75kW
		Number of tools	ER11×3 tools	ER11×4 tools	ER11×3 tools (Option ER11×4 tools) (Option ER16×4 tools)	ER11×3 tools (Option: ER11×4 tools) (Option: ER16×4 tools)	ER16×4 tools	ER16×4 tools (Option: ER16×5 tools)
\$2	O.D.	Number of tools	-	-	-	-	-	1 tool (removed for K)
		Bite size	-	-	-	-	-	□10
	I.D.	Number of tools	-	ER11×4 tools	-	ER16×2 tools	-	ER16×3 tools (ER16×2 tools for K)
		Max. rpm	-	-	-	6,000rpm	-	(6,000rpm for K)
	Cross	Power	-	-	-	0.4kW	-	(0.4kW for K)
		Number of tools	-	-	-	-	-	-
ECC	Number of tools	-	-	-	ER16×2 tools	-	(ER16×2 tools for K)	
No. of Axis (C1, C2 excluded)		4	5	4	5	3	5	
Stroke (mm)	Z1	120	200	110	110	200	200	
	X1	32	133	114	114	133	133	
	Y1	157	252.5	255	255	252.5	252.5	
	Z2	120	263.5	170	250	-	263.5	
	X2	-	222	-	187	-	222	
	Y2	-	-	-	-	-	-	
Dimension	Size (LxWxH)	1,500x980x1,590	1,700x770x1,650	1,775x980x1,660	1,990x1,000x1,635	1,650x1,030x1,680	2,162x1,090x1,675	
	Weight	1,000kg	1,500kg	1,700kg	1,950kg	1,350kg	2,135kg	
<b>Remark</b>								
• O.D tool post		Wedge	Wedge	Holder	Holder	Holder	Holder	
				Wedge	Wedge	Wedge	Wedge	
• Application		• Small precision combined turning	• Small precision combined turning	• Small precision combined turning	• Multi-functional combined turning	• Simple precision turning	• Diffusion model for combined turning	
		• Best spec in its class	• Best spec in its class	• Best spec in its class				

Content	NAME	NN-20J3	NN-20J3XB	NN-32UB8K2	NN-32YB3	NN-32YB3XB	NN-38UB8K2	
	TYPE	S	S	S	S/N	S/N	S/N	
	NC	Mitsubishi M70V TypeA / FANUC Oi-TF	Mitsubishi M80	Mitsubishi M70V TypeA / FANUC Oi-TF	Mitsubishi M70V TypeA / FANUC Oi-TF	Mitsubishi M70V TypeA	Mitsubishi M80	
Specification	Photo							
	\$1 Tool Lay-out [MAIN]							
	\$2 TOOL LAY-OUT [SUB]							
	Max. Machining capacity (Ø)	Ø16 / Ø20	Ø20	Ø32	Ø25 / Ø32	Ø32	Ø38	
\$1	Max. rpm	10,000rpm	10,000rpm	8,000rpm	8,000rpm	8,000rpm	8,000rpm	
	Power	3.7/1.5kW	3.7/1.5kW	5.5/3.7kW	5.5/3.7kW	5.5/3.7kW	7.5/5.5kW	
\$2	Max. rpm	10,000rpm	10,000rpm	6,000rpm	8,000rpm	8,000rpm	8,000rpm	
	Power	3.7/1.5kW	3.7/1.5kW	3.7/1.5kW	3.7/1.5kW	3.7/1.5kW	5.5/3.7kW	
Max. Number of tools		30 tools	29 tools	23 tools	30 tools	39 tools	26 tools	
\$1	O.D.	Number of tools	6 tools	5 tools	5 tools (□12.7×3, □16×2)	5 tools	6 tools	5 tools
		Bite size	□12.7	□12.7	□12.7, □16	□16	□16	□20
	I.D.	Number of tools	ER16×4 tools+4 tools	ER16×4 tools+4 tools	ER16×3 tools+ER20×1 tools	ER16×3 tools ER20×1 tool	ER16×5 tools+(op 5 tools) ER20×1 tools+(op 1 tools)	ER16×3 tools ER20×2 tools
		Max. rpm	6,000rpm	6,000rpm	6,000rpm	6,000rpm	6,000rpm	6,000rpm
		Power	0.75kW	1.5kW	1.5kW	1.5kW	1.5kW	1.5kW
		Number of tools	ER16×5 tools	ER16×5 tools	ER16×4 tools	ER20×6 tools	ER20×5 tools ER11×5 tools	ER20×5 tools
\$2	O.D.	Number of tools	2 tools	2 tools	-	2 tools	2 tools	-
		Bite size	□12.7	□12.7	-	□16	□16	-
	I.D.	Number of tools	ER16×3 tools	ER16×3 tools	ER16×3 tools	ER16×3 tools	ER16×3 tools	ER20×2tools ER16×1 tools
		Max. rpm	6,000rpm	6,000rpm	6,000rpm	6,000rpm	6,000rpm	6,000rpm
		Power	0.75kW	1.5kW	0.9kW	1.5kW	1.5kW	0.9kW
		Number of tools	ER16×3 tools	ER16×3 tools	-	ER16×3 tools	ER16×3 tools	-
ECC	Number of tools	ER11×3 tools	ER11×3 tools	ER16×3 tools	ER16×3 tools	ER16×3 tools	ER20×3 tools	
No. of Axis (C1, C2 excluded)		6	7	5	6	7	5	
Stroke (mm)	Z1	205	205	194	190	190	260	
	X1	169	169	133	92.5	96	236	
	Y1	288	288	261.5	223	293	370	
	Z2	300	300	228.5	315.5	349.9	350	
	X2	221	221	222	185	184	400	
	Y2	228	228	-	241	265	-	
Dimension	Size (LxWxH)	2,390x1,500x1,855	2,365x1,478x2,005	2,330x1,047x1,676	2,270x1,425x1,825	2,278x1,656x1,990	2,660x1,528x2,038	
	Weight	2,700kg	2,800kg	2,350kg	3,030kg	3,050kg	3,600kg	
<b>Remark</b>								
• O.D tool post		Holder		Holder	Holder	Holder	Holder	
		Wedge		Wedge	Wedge	Wedge	Wedge	
• Application		• Multi-functional combined turning	• Multi-functional combined turning	• Diffusion model for combined turning	• Multi-functional combined turning	• Multi-functional combined turning	• Multi-functional combined turning	
		• Best spec in its class	• Best spec in its class		• Best spec in its class	• Best spec in its class	• Best spec in its class	
		• Shortened cycle time	• Shortened cycle time		• Shortened cycle time	• Shortened cycle time	• Shortened cycle time	

# NN-3X

**Specialized for miniature and high-precision parts**  
 - Horizontal tool post

**The best tool layout among equivalent models**  
 - The largest number of tools: 17EA  
 - Drastically shortened cycle time

**Expanded tool options**



## TOOL Layout

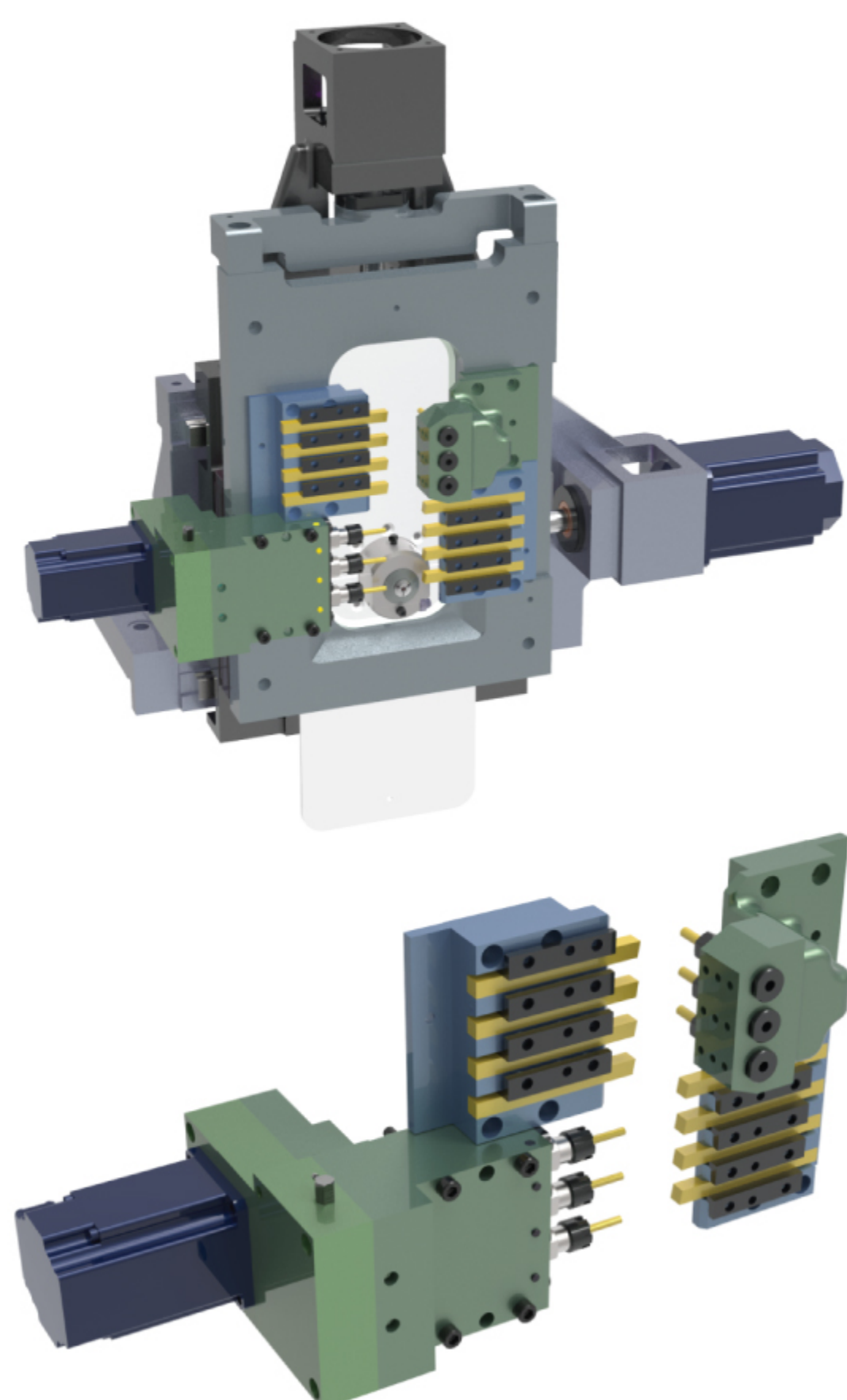
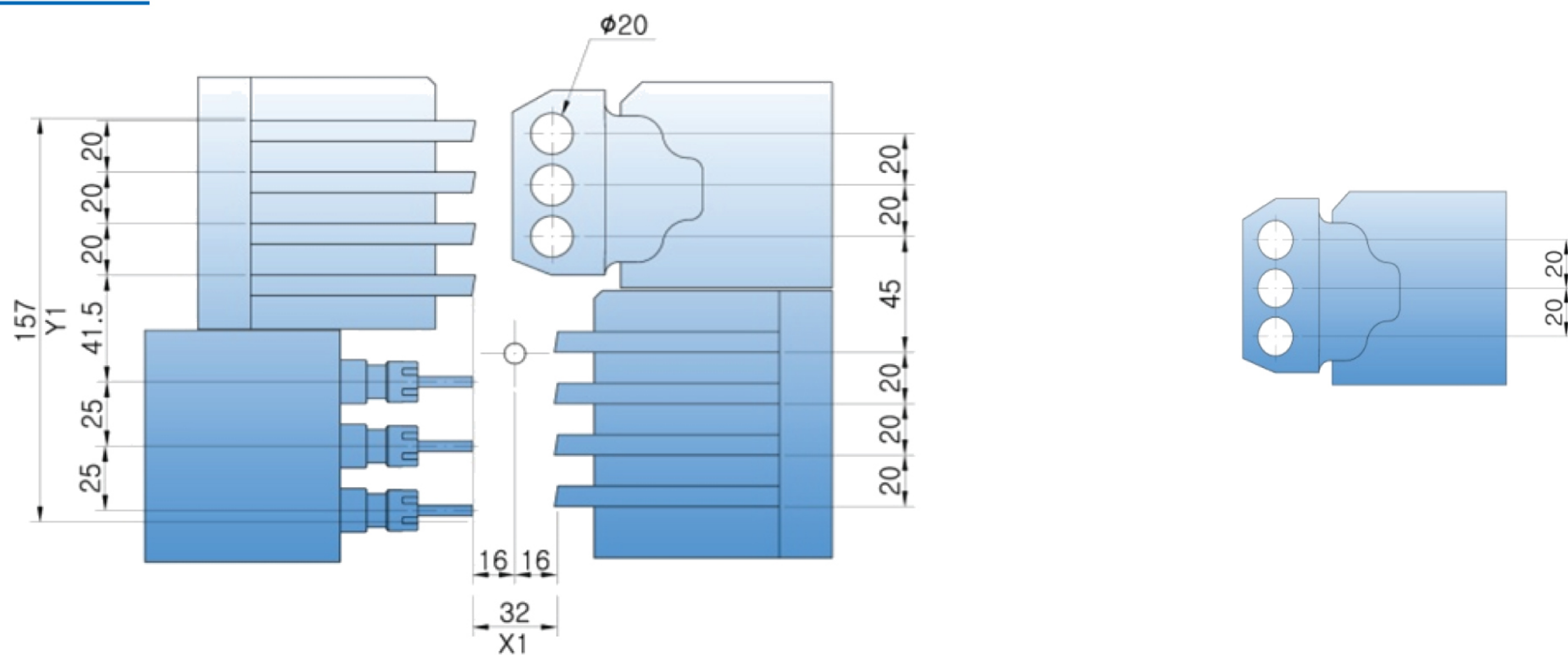

### \$1 (Main)

Tool name	Size	Equipment
O.D. Tool	□8 x 8	Standard
I.D. Tool	ER8 x 3	Standard
Cross Drill	ER11 x 3	Standard

### \$2 (Sub)

Tool name	Size	Equipment
I.D. Tool	ER8 x 3	Standard

## NN-3X Specifications

Content	Specification	Specification Value	Standard Accessories
Machining capacity	Max. machining diameter	Φ3mm	I.D. tool unit
	Max. machining length	30mm / 1chuck	Cross drill unit
	Max. parts unloading length	30mm	Manual pulse generator(MPG)37P
Spindle	Main spindle through-hole diameter	Φ4mm	Coolant unit
	Spindle rpm (Main/Sub)	Max. 20,000rpm	Drill holder
	Sub spindle chucking diameter	Φ3mm	Main : Chuck sleeve /Spring/Spindle cap (1set)
Tool	Max. number of tools	17	Sub : Chuck sleeve /Spring/Spindle cap (1set)
	Max. machining drill	Φ2mm	Automatic power turn-off device
	Max. machining tap	M2	Automatic oiling device (level detector attached)
Main	O.D. tool	8 (□8X100mm max)	Overload detection function
	I.D. tool	3 (ER8)	Working light (LED)
	Cross drill	3 (ER11)	Parts catcher
	Cross drill rpm	Max. 9,000rpm	Levelling pad
SUB	O.D. tool	-	Signal warning light - 3 stage
	I.D. tool	3 (ER8)	Display language (CHN/ENG/FRA/GER/ITA/JPN/KOR/POL/RUS/SPA)
	I.D. eccentric tool	-	
	Cross drill	-	
	Cross drill rpm	-	
Feed	Rapid feed rate	20m/min	
	Min. command unit	0.001mm	
	C axis Min. command unit (Main, Sub)	0.001°	
Motor	Main spindle motor	1.1/0.75kW	<b>Optional Accessories</b>
	Cross drill motor	0.35kW	Automatic fire extinguisher
	Sub spindle motor	1.1/0.75kW	Oil mist collector
	\$2 cross drill motor	-	Custom colors
	X1, Z1, Z2 axis feed motor	0.5kW	Tooling
	Y1 axis feed motor	0.75kW	Door interlock switch
	Coolant pump (Main, Sub)	0.25kW	Parts conveyor
	Lubricant pump	0.003kW	
Dimensions and etc.	Main spindle center height	950mm	
	Input power capacity	9KVA	
	Air pressure, flow rate	0.6MPa.30L/min	
	Coolant tank	65L	
	WxDxH	1,500x980x1,590 mm	
	Weight (Options included)	1,000kg	
NC	NC ( FANUC )	FANUC 0i-TF	
	NC display	8.4 Color TFT LCD	
	Memory capacity	1MB	
	Number of tool offset	128sets	
	Background edit function		
	C axis function (Main, Sub spindle)		
	User macro function		
	Nose R compensation		
	Corner chamfering /Corner rounding		
	Fixed cycle		
	Complex fixed cycle		
	Geometric commands		
	Controller manual		
	Serial in / Output interface		
CF card / USB interface			

## FLOOR Layout

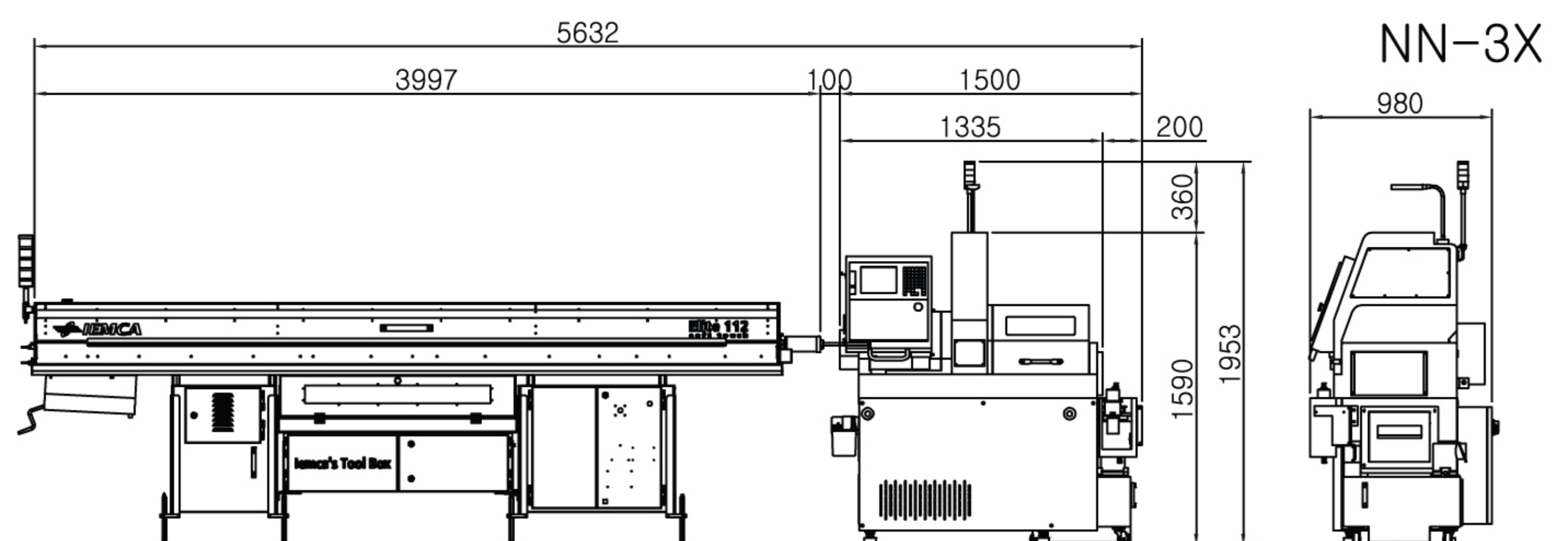



## NN-10EX2 Specifications

Content	Specification	Specification Value	Standard Accessories
Machining capacity	Max. machining diameter	Φ10mm	I.D. tool unit
	Max. machining length	RB : 110mm / 1chuck FB : 135mm / 1chuck	Tool holder
	Max. parts unloading length	50mm	Rotary guide bush
Spindle	Main spindle through-hole diameter	Φ13mm	Rotary guide bush drive unit
	Spindle rpm (Main/Sub)	Max. 15,000rpm/15,000rpm	Drill holder
	Sub spindle chucking diameter	Φ10mm	Main : Chuck sleeve /Spring/Spindle cap(1set)
Tool	Max. number of tools	22	Sub : Chuck sleeve /Spring/Spindle cap(1set)
	Max. machining drill	Φ7mm	Automatic power turn-off device
	Max. machining tap	M6	Automatic oiling device (level detector attached)
Main	O.D. tool (□10x130mm or less)	6	Cutting oil device
	I.D. tool (ER11)	4	Coolant failure detector
	Cross drill (ER11)	4	Overload detection function
	Cross drill rpm	Max. 10,000rpm	Door interlock switch
SUB	I.D. tool	4	Working light (LED)
	I.D. rotary tool		Parts catcher
	Max. frontal hole machining diameter	Φ7mm	Working tools
	Max. frontal tap diameter	M6	Levelling pad
Feed	Rapid feed rate	28m/min	Signal warning light - 3 stage
	Min. command unit	0.0001mm	Display language (CHN/ENG/FRA/GER/ITA/JPN/KOR/POL/RUS/SPA)
	C axis Min. command unit (Main, Sub)	0.0001°	<b>Optional Accessories</b>
Motor	Main spindle motor	3.7/1.5kW	O.D. tool post (6EA)
	Cross drill motor	0.4kW	3-spindle drilling unit (Eccentric)
	Sub spindle motor	1.1/0.75kW	Long drill holder
	\$2 rotary motor	0.4kW	Fixed guide bush
	Y1,Y1,Z1,Z2 axis feed motor	0.5kW	Tap breakage detector
	Coolant pump (Main, Sub)	0.25kW	Tool air blow
	Lubricant pump	0.003kW	Rear ejection unit (Φ7mm or less)
Dimensions and etc.	Main spindle center height	1,000mm	Spindle tube liner for small part
	Input power capacity	6.8KVA	Large-sized lubricant pump 1.8ℓ
	Air pressure, flow rate	0.6MPa.30L/min	Chip conveyor & Chip box
	Coolant tank	110L	Medium / High pressure coolant
	WxDxH	1,700 x 770 x 1,650mm	Automatic fire extinguisher
	Weight (Options included)	1,500kg	Oil mist collector
NC	MITSUBISHI NC	M80	Custom colors
	NC display	8.4 Color TFT LCD	Tooling
	Memory capacity	500KB	
	Number of tool offset	256sets	

## FLOOR Layout

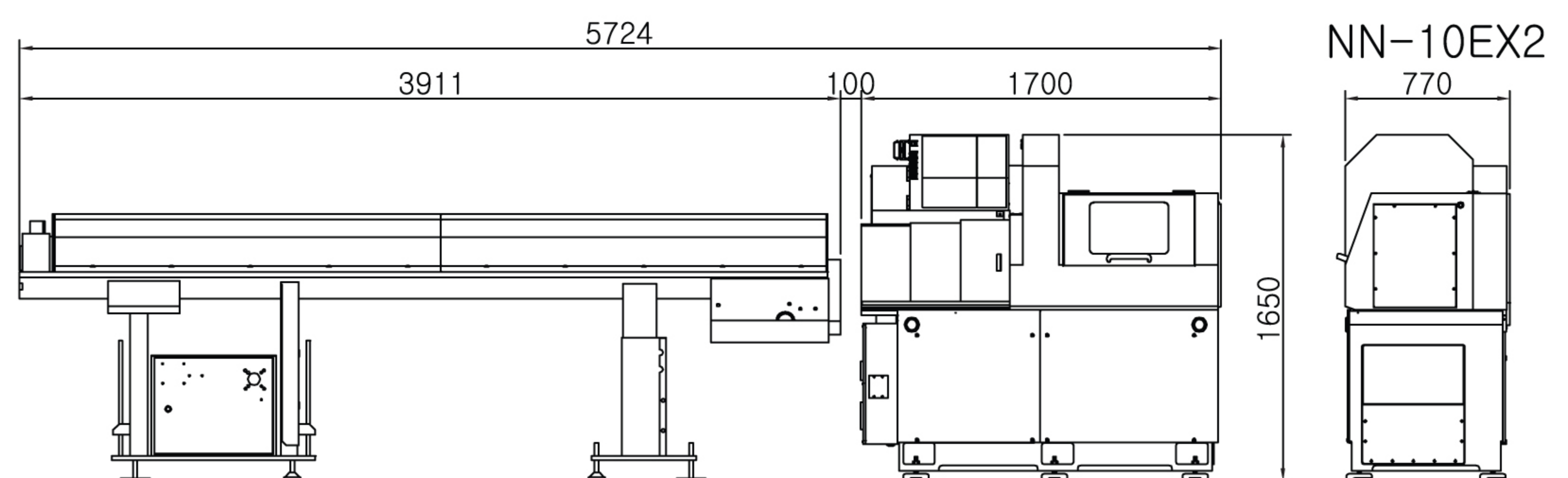



## NN-16SB6 Specifications

Content	Specification	Specification Value		Standard Accessories
		Type1	Type3	
Machining capacity	Max. machining diameter	Φ16mm		I.D. tool unit
	Max. machining length	110mm / 1chuck		Tool holder
	Max. parts unloading length	160mm	80mm	Rotary guide bush
Spindle	Main spindle through-hole diameter	Φ17mm		Rotary guide bush drive unit
	Spindle rpm (Main/Sub)	Max. 10,000rpm / Max. 7,000rpm		Drill holder
	Sub spindle chucking diameter	Φ16mm		Main : Chuck sleeve /Spring/Spindle cap(1set)
Tool	Max. number of tools	15	16	Sub : Chuck sleeve /Spring/Spindle cap(1set)
	Max. machining drill	Φ7mm		Automatic power turn-off device
	Max. machining tap	M6		Automatic oiling device (level detector attached)
Main	O.D. tool (□12.7x130mm or less)	7	5	Cutting oil device
	I.D. tool (ER11)	4	4	Coolant failure detector
	Cross drill (ER11)	—	3(OP:4)	Overload detection function
	Cross drill rpm	Max. 8,000rpm		Door interlock switch
SUB	I.D. tool	4	4	Working light (LED)
	Max. frontal hole machining diameter	Φ6mm		Parts catcher
	Max. frontal tap diameter	M5mm		Working tools
Feed	Rapid feed rate	24m/min		Levelling pad
	Min. command unit	0.0001mm		Signal warning light - 3 stage
	C axis Min. command unit (Main, Sub)	0.0001°		Display language (CHN/ENG/FRA/GER/ITA/JPN/KOR/POL/RUS/SPA)
Motor	Main spindle motor	2.2/1.5kW		<b>Optional Accessories</b>
	Cross drill motor	—	0.4kW	Main
	Sub spindle motor	—	0.75/0.3kW	
	Y1,Y1,Z1,Z2 axis feed motor	0.5kW		Long drill holder
	Coolant pump	0.25kW		Fixed guide bush
	Lubricant pump	0.003kW		Tap breakage detector
	Hydraulic oil pump	—	0.75kW	Tool presetter
Dimensions and etc.	Main spindle center height	1,000mm		Tool air blow
	Input power capacity	4.43KVA	7.1KVA	Rear ejection unit (Φ11mm or less)
	Air pressure, flow rate	0.6MPa.15L/min		Spindle tube liner for small part
	Coolant tank	70L		Large-sized lubricant pump 1.8ℓ
	WxDxH	1,775x980x1,660 mm		Chip conveyor & Chip box
	Weight (Options included)	1,700kg		Medium / High pressure coolant
NC	MITSUBISHI NC	M70V Type A		Automatic fire extinguisher
	NC display	8.4 Color TFT LCD		Oil mist collector
	Memory capacity	500KB		Custom colors
	Number of tool offset	80sets		Tooling

### FLOOR Layout

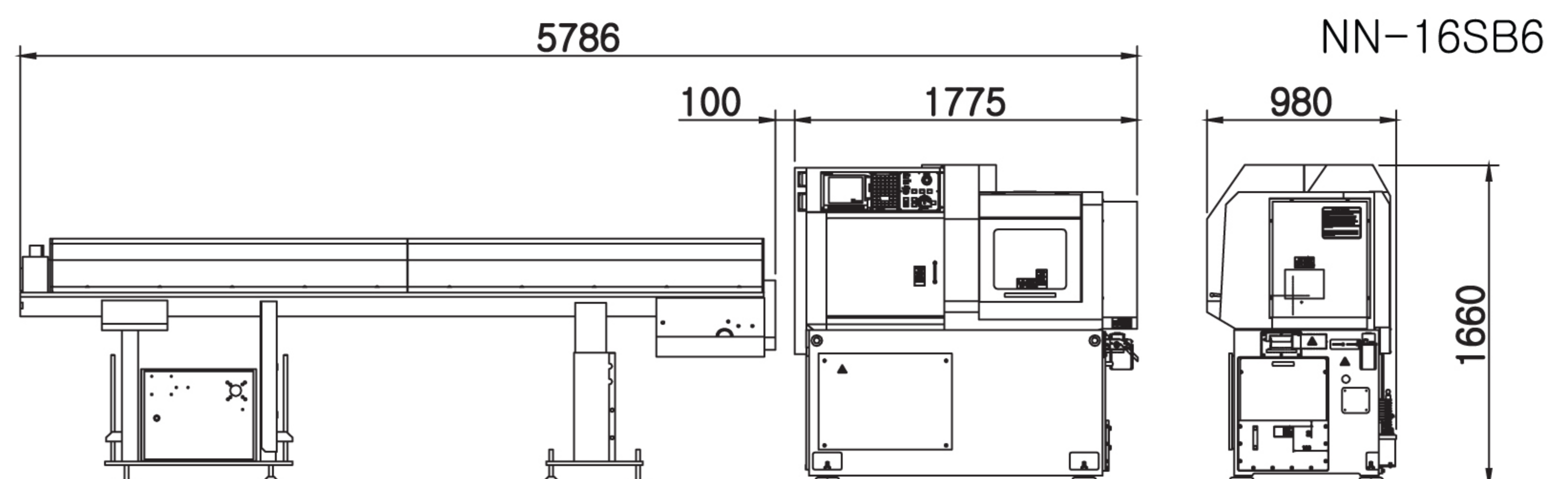

# NN-16SB7

**Specialized for complicated shape parts under  $\Phi 16$**   
 - Sub tool post and X2 axis for back machining

**Slant type tool post for easy chip removal**

**Slotting machining on sub-spindle (option)**



## TOOL Layout

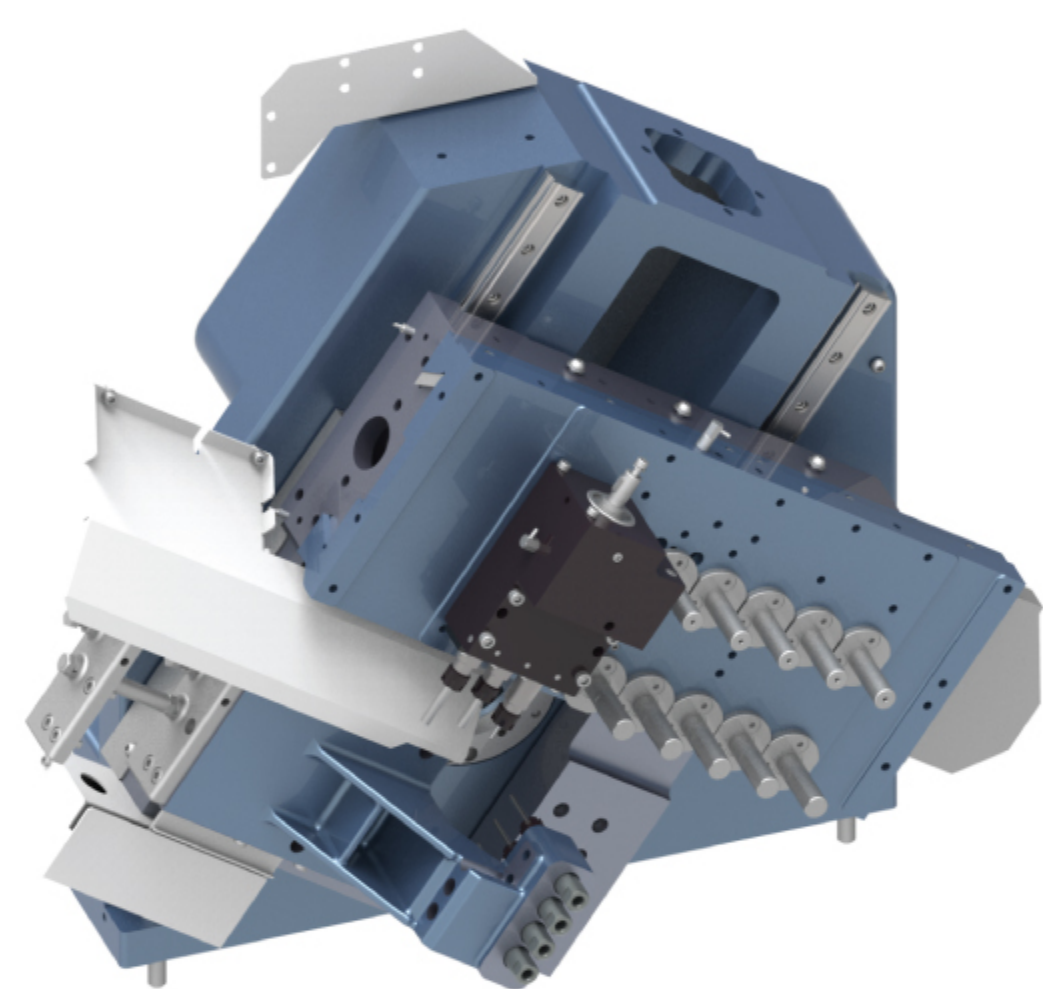
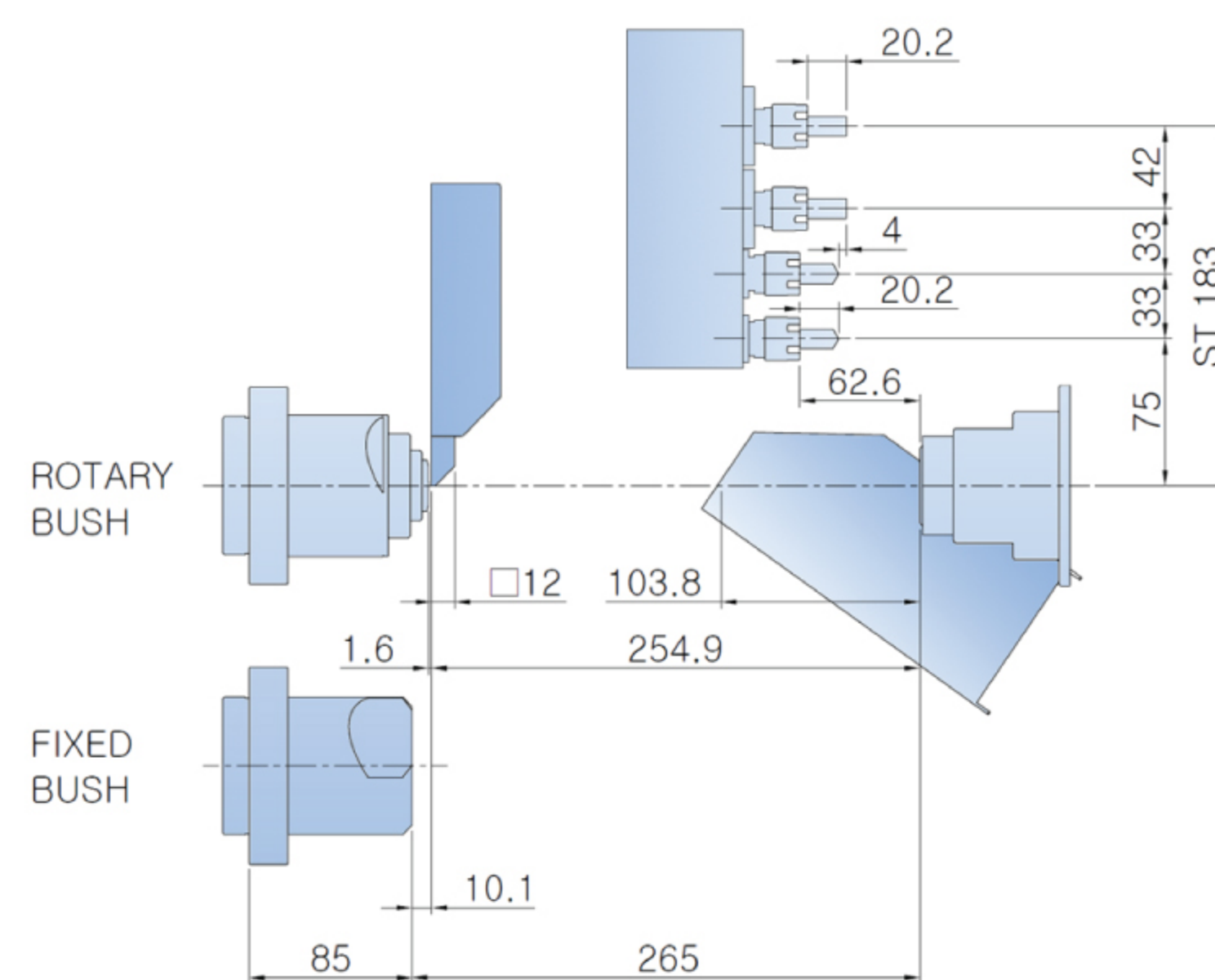
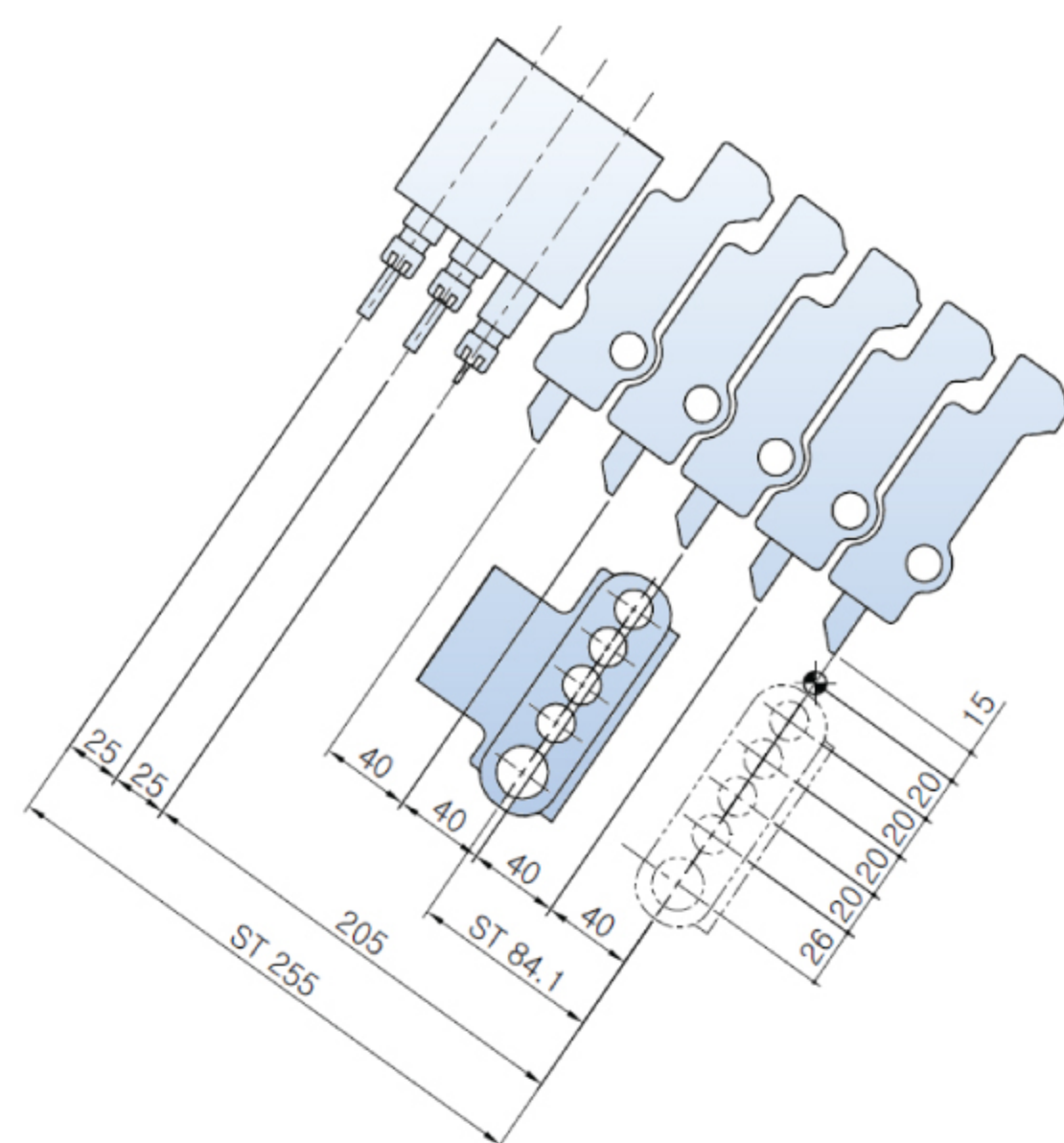

### \$1 (Main)

Tool name	Size	Equipment
O.D. Tool	$\square 12.7 \times 5$	Standard
I.D. Tool	ER11 x 4	Standard
Cross Drill	ER11 x 3	

### \$2 (Sub)

Tool name	Size	Equipment
I.D. Tool	ER16 x 2	Standard
I.D. Rotary Tool	ER16 x 2	Standard



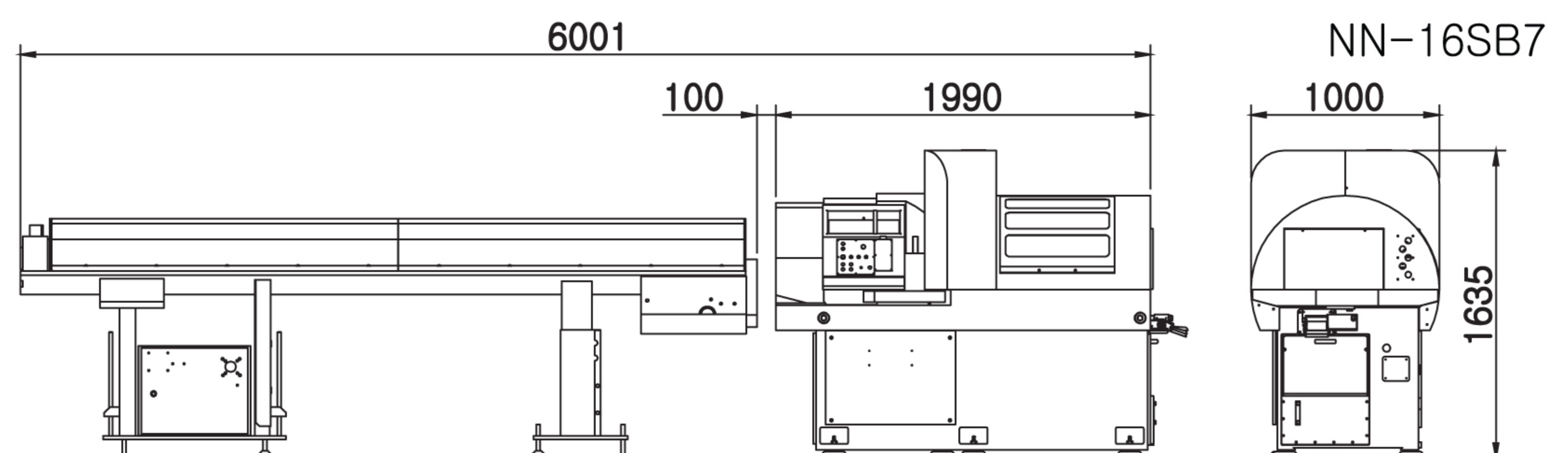

## NN-16SB7 Specifications

Content	Specification	Specification Value	Standard Accessories
Machining capacity	Max. machining diameter	Φ16mm	I.D. tool unit
	Max. machining length	110mm / 1chuck	Cross drill unit
	Max. parts unloading length	80mm	Manual Pulse Generator (MPG)
Spindle	Main spindle through-hole diameter	Φ17mm	Cutting oil device
	Spindle rpm (Main/Sub)	Max. 10,000rpm / 7,000rpm	Rotary guide bush
	Sub spindle chucking diameter	Φ16mm	Tool holder
Tool	Max. number of tools	20 (OP:22)	Drill holder
	Max. machining drill	Φ7mm	Main : Chuck sleeve /Spring/Spindle cap(1set)
	Max. machining tap	M6	Sub : Chuck sleeve /Spring/Spindle cap(1set)
Main	O.D. tool	5 (□12.7X130mm max)	Automatic power turn-off device
	I.D. tool	4 (ER11) / OP:5	Automatic oiling device (level detector attached)
	Cross drill	3 (ER11)	Coolant device
	Cross drill rpm	Max. 8,000rpm	Coolant failure detector
SUB	I.D. tool	2 (ER16)	Overload detection function
	I.D. rotary tool	2 (ER16)	Door interlock switch
	Cross drill rpm	Max. 6,000rpm	Working light (LED)
Feed	Rapid feed rate	24m/min	Parts catcher
	Min. command unit	0.0001mm(Mitsubishi) / 0.001mm(Fanuc)	Levelling pad
	C axis Min. command unit (Main, Sub)	0.0001°(Mitsubishi) / 0.001° (Fanuc)	Signal warning light - 3 stage
Motor	Main spindle motor	2.2/1.5kW(Mitsubishi) / 2.2/1.5kW(Fanuc)	Manual pulse generator(MPG)37P
	Cross drill motor	0.4kW(Mitsubishi) / 1.0kW(Fanuc)	Display language (CHN/ENG/FRA/GER/ITA/JPN/KOR/POL/RUS/SPA)
	Sub spindle motor	0.75/0.3kW(Mitsubishi) / 1.1/0.5kW(Fanuc)	<b>Optional Accessories</b>
	\$2 rotary motor	0.4kW(Mitsubishi) / 0.5kW(Fanuc)	Fanuc Oi-TF
	X1,X2,Y1,Z1,Z2 axis feed motor	0.5kW(Mitsubishi) / 0.75kW(Fanuc)	4-spindle cross drilling unit (ER16X4)
	Coolant pump (Main, Sub)	0.25kW	3-spindle drilling unit (E3 UNIT)
	Lubricant pump	0.003kW	Long drill holder
Dimensions and etc.	Main spindle center height	1,000mm	Fixed guide bush
	Input power capacity	10KVA	Tap breakage detector
	Air pressure, flow rate	0.6MPa.30L/min	Tool presetter
	Coolant tank	100L	Tool air blow
	WxDxH	1,990 x 1,000 x 1,635mm	Parts conveyor
	Weight (Options included)	1,950kg	Rear ejection unit (Φ11mm or less)
NC	NC (MITSUBISHI/FANUC)	M70 Type A(Mitsubishi) / Oi TF (Fanuc)	Spindle tube liner for small part
	NC display	8.4 Color TFT LCD	Large-sized lubricant pump 1.8ℓ
	Memory capacity	500KB(Mitsubishi) / 1MB(Fanuc)	Chip conveyor & Chip box
	Number of tool offset	80sets(Mitsubishi) / 128sets(Fanuc)	Medium / High pressure coolant
	Background edit function		Automatic fire extinguisher
	C axis function (Main, Sub spindle)		Oil mist collector
	User macro function		Custom colors
	Nose R compensation		Tooling
	Corner chamfering /Corner rounding		
	Fixed cycle		
	Complex fixed cycle		
	Geometric commands		
	Controller manual		
	Serial in/ Output interface		
CF card / USB interface			

### FLOOR Layout



# NN-20/25UB8

-  **NC controller selectable**  
- MITSUBISHI, FANUC
-  **Expanded tool options**  
- Eccentric turning operation on sub tool
-  **Guide / Non-guide bush type**  
- Minimized remaining material (Non-guide bush type)
-  **Specialized for high-precision parts**
-  **High efficiency, reasonable price**



## TOOL Layout

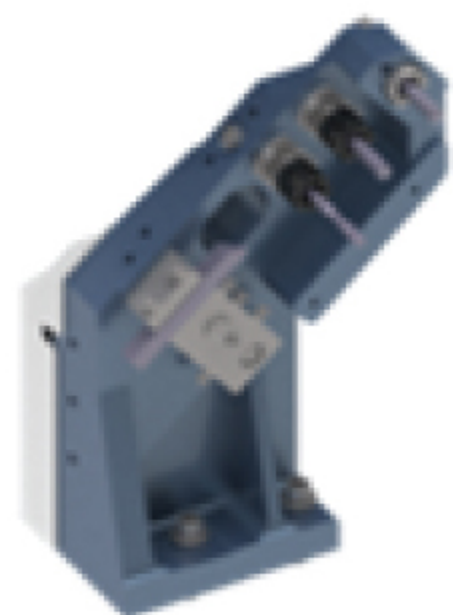
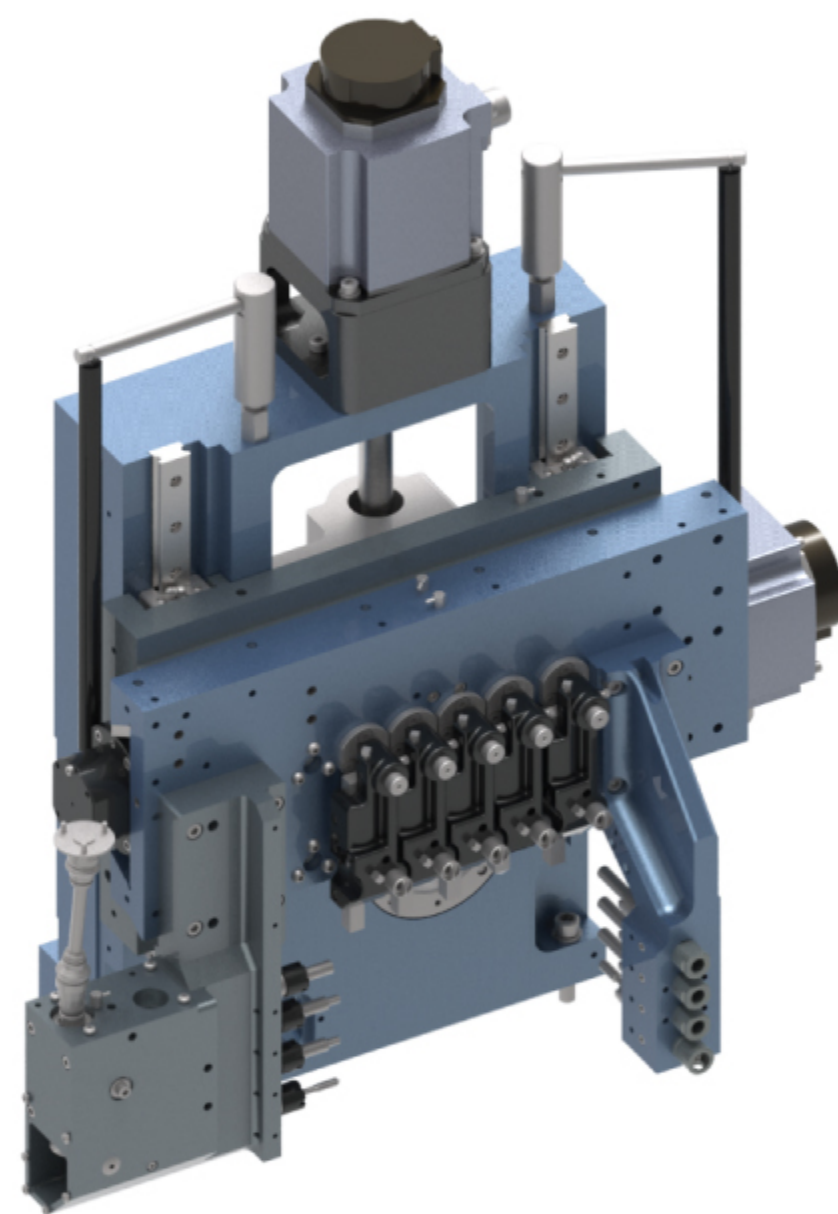
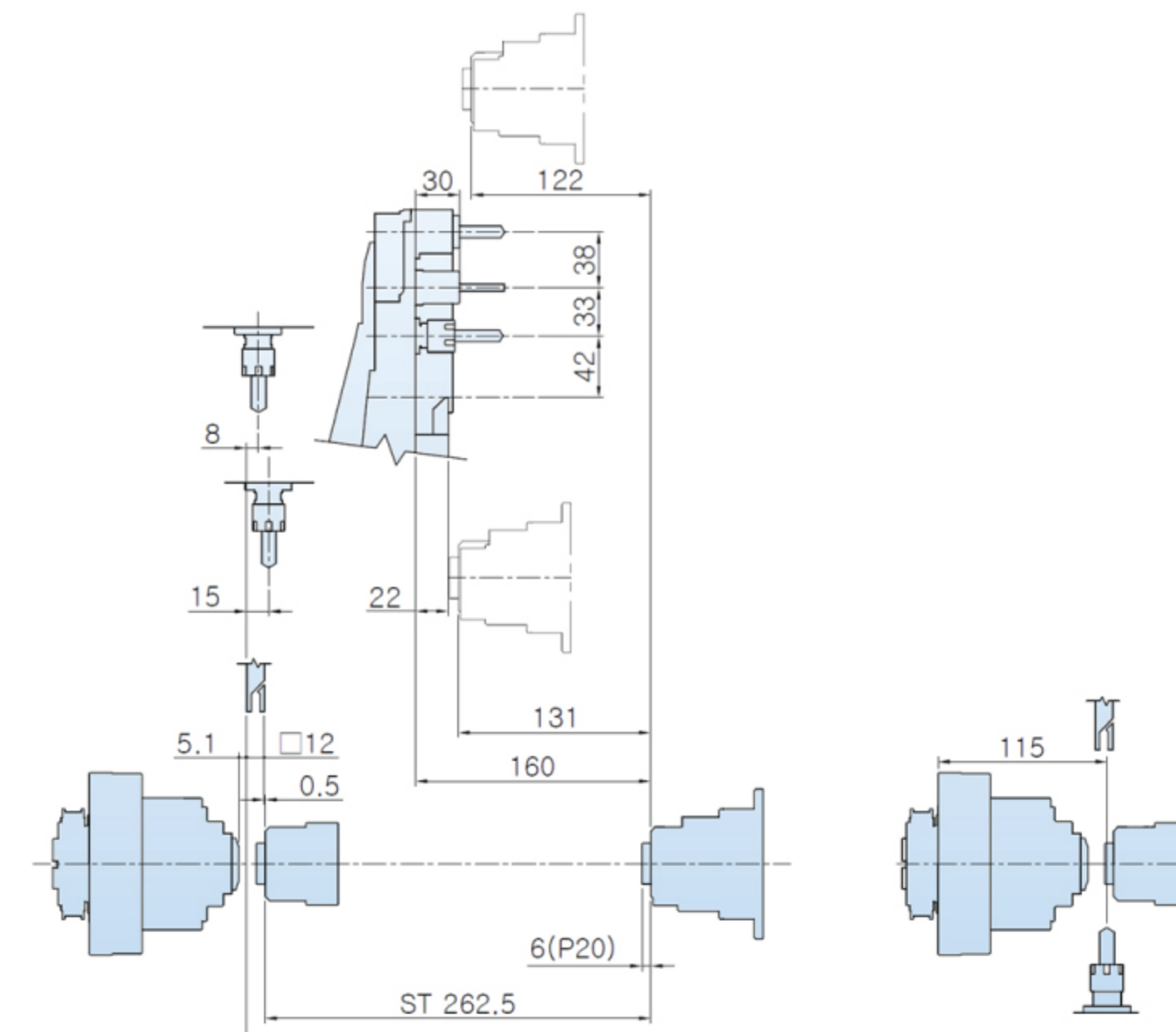
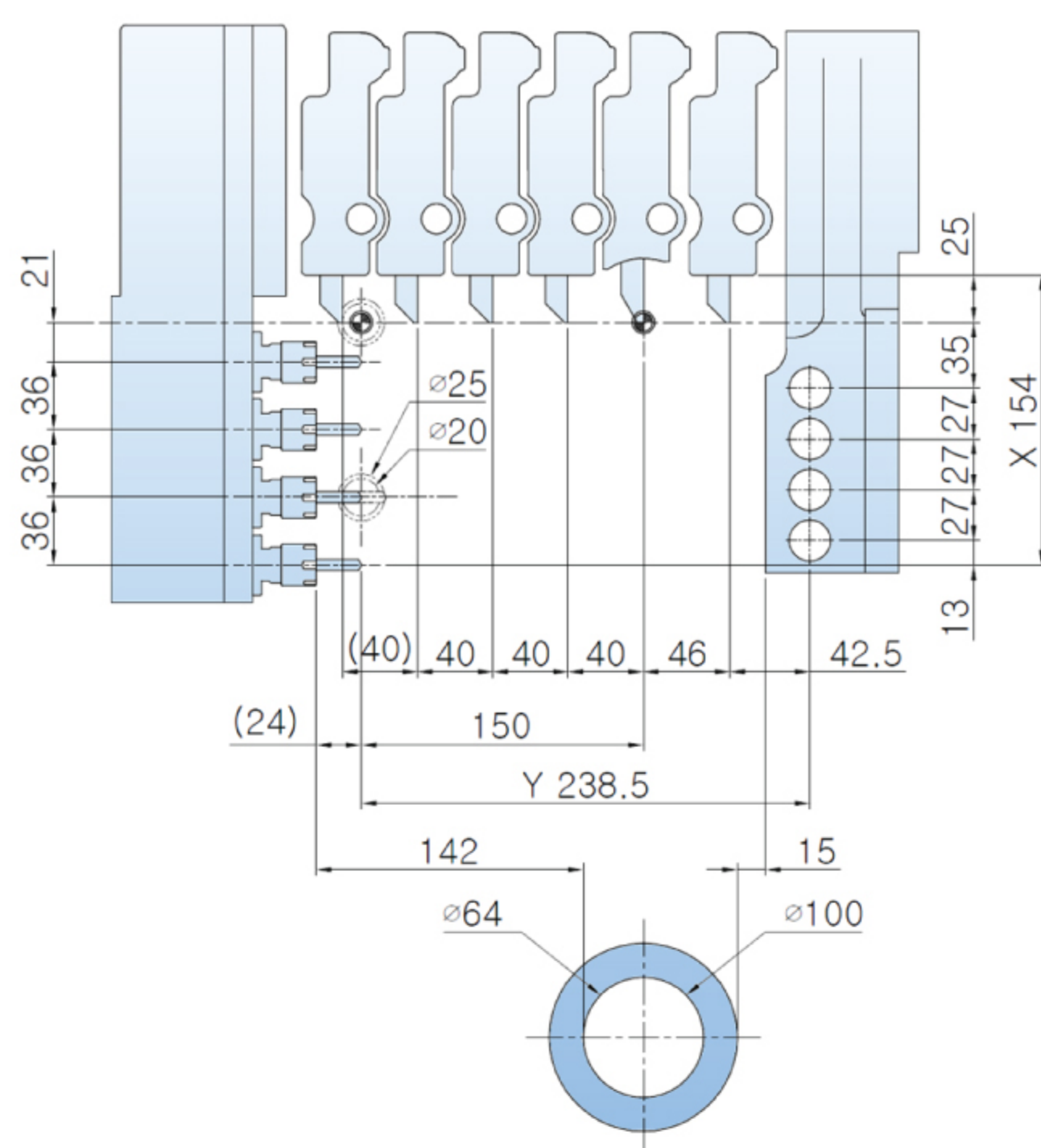

Standard  
4 fixed tools

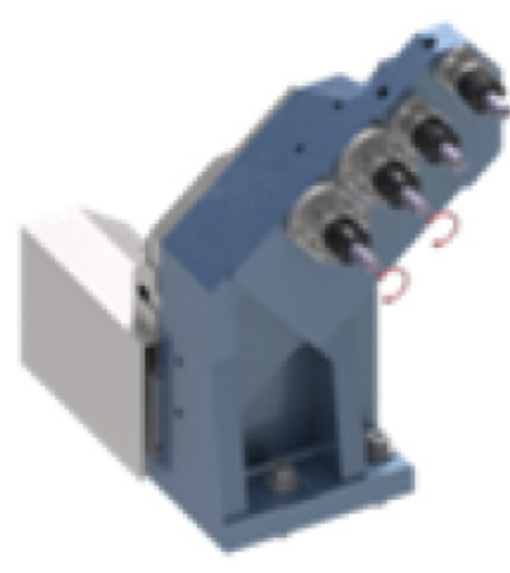

K type  
Rotary motor added

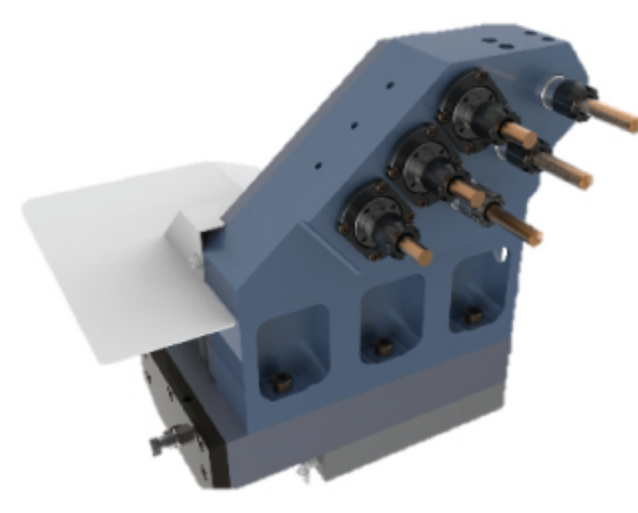

K2 type  
Rotary motor added

### \$1 (Main)

Tool name	Standard Size	Option Size	Equipment
O.D. Tool	□ 12.7 x 5 (Φ20) □ 12.7 x 3 + □ 16 x 2 (Φ25)		Standard
I.D. Tool	ER16 x 4		Standard
Cross Drill	ER16 x 4	ER16 x 5	Standard



5 hole cross unit  
(20UB8 Option only)

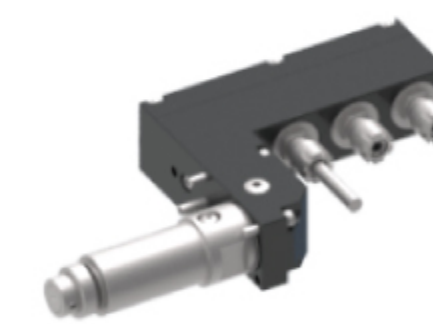

3-spindle drilling unit  
(E3 unit - Option)  
for eccentric machining

### \$2 (Sub)

Tool name	Standard Size	K Type
I.D. Tool	ER16 x 4	ER16 x 2
I.D. Rotary Tool		ER16 x 2

## NN-20/25UB8 Specifications

Content	Specification	Specification Value		Standard Accessories
		20UB8(K)	25UB8(K)	
Machining capacity	Max. machining diameter	Φ20mm	Φ25mm	I.D. tool unit
	Max. machining length	200mm / 1chuck		Cross drill unit
	Max. parts unloading length	105mm		Manual pulse generator(MPG)37P
Spindle	Main spindle through-hole diameter	Φ24mm	Φ27mm	Coolant unit
	Spindle rpm (Main/Sub)	Max. 10,000/6,000rpm		Rotary guide bush
	Sub spindle chucking diameter	Φ20mm	Φ25mm	Tool holder
Tool	Max. number of tools	23	23	Drill holder
	Max. machining drill	Φ10mm		Main : Chuck sleeve /Spring/Spindle cap(1set)
	Max. machining tap	M8		Sub : Chuck sleeve /Spring/Spindle cap(1set)
Main	O.D. tool	5 (□12.7X150mm)	5 (□12.7x3+□16X2X150mm max)	Automatic power turn-off device
	I.D. tool	4 (ER16)		Automatic oiling device (level detector attached)
	Cross drill	4 (ER16)		Cutting oil device
	Cross drill rpm	Max. 6,000rpm		Coolant failure detector
SUB	I.D. tool	4(ER16) / K : 4 (2 fixed + 2 rotary)		Overload detection function
	Rotary tool			Door interlock switch
Feed	Rapid feed rate	30m/min		Working light (LED)
	Min. command unit	0.0001mm(Mitsubishi) / 0.001mm(Fanuc)		Parts conveyor
	C axis Min. command unit (Main, Sub)	0.0001°(Mitsubishi) / 0.001°(Fanuc)		Levelling pad
Motor	Main spindle motor	3.7/2.2kW(Mitsubishi) / 3.7/2.2kW(Fanuc)		Signal warning light - 3 stage
	Cross drill motor	0.75kW(Mitsubishi) / 1.0kW(Fanuc)		Display language (CHN/ENG/FRA/GER/ITA/JPN/KOR/POL/RUS/SPA)
	Sub spindle motor	1.5/0.55kW(Mitsubishi) / 2.2/1.5kW(Fanuc)		<b>Optional Accessories</b>
	\$2 rotary motor	0.4kW(Mitsubishi) / 0.5kW(Fanuc)		Fanuc Oi-TF
	Y1,X2,Z2 axis feed motor	0.5kW(Mitsubishi) / 1.4kW(Fanuc)		5-spindle cross drilling unit
	X1,Z1 axis feed motor	1.0kW(Mitsubishi) / 1.4kW(Fanuc)		3-spindle drilling unit (E3 UNIT)
	Coolant pump (Main, Sub)	0.25kW		Long drill holder
	Lubricant pump	0.003kW		Fixed guide bush
Dimensions and etc.	Main spindle center height	1,000mm		Tap breakage detector
	Input power capacity	12KVA		Tool presetter
	Air pressure, flow rate	0.6MPa.35L/min		Tool air blow
	Coolant tank	110L		Rear ejection unit (20UB8: Φ17 / 25UB8: Φ20 or less)
	WxDxH	2,162x 1,090 x1,675 mm	2,300x1,090x1,675 mm	Spindle tube liner for small part
	Weight (Options included)	2,135kg		Large-sized lubricant pump 1.8ℓ
NC	NC(MITSUBISHI/FANUC)	M70V Type A		Chip conveyor & Chip box
	NC display	8.4 Color TFT LCD		Medium / High pressure coolant
	Memory capacity	500KB(Mitsubishi) / 1MB(Fanuc)		Automatic fire extinguisher
	Number of tool offset	80sets(Mitsubishi) / 128sets(Fanuc)		Oil mist collector
	Background edit function			Custom colors
	C axis function (Main, Sub spindle)			Tooling
	User macro function			
	Nose R compensation			
	Corner chamfering /Corner rounding			
	Fixed cycle			
	Complex fixed cycle			
	Geometric commands			
	Controller manual			
	Serial in / Output interface			
CF card / USB interface				

### FLOOR Layout

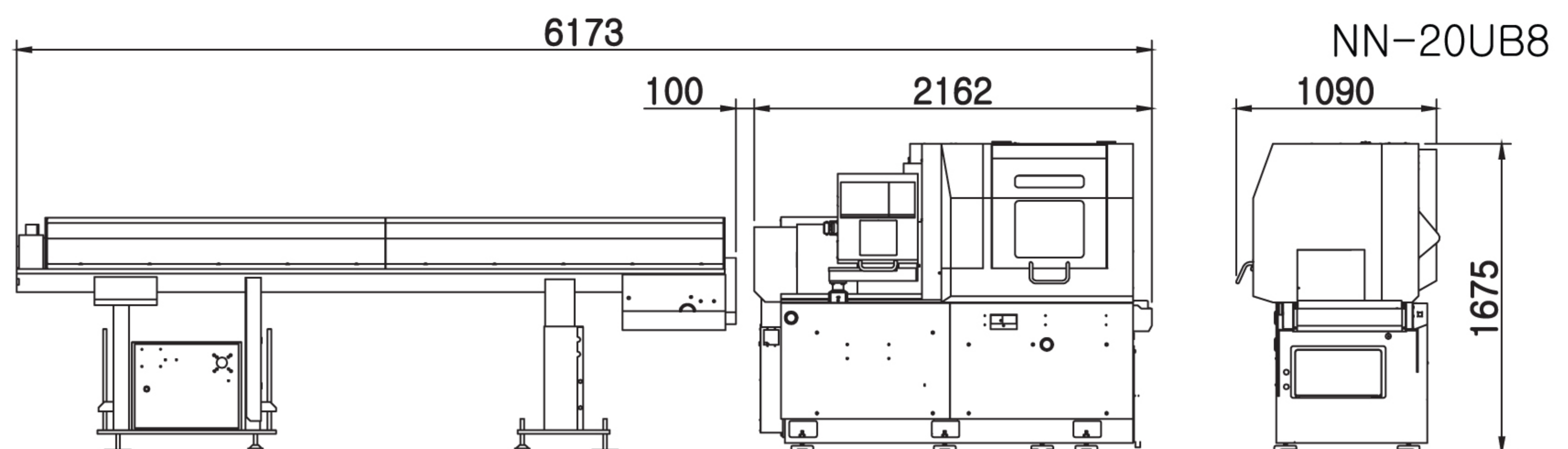

# NN-20J3

-  **NC controller selectable**  
- MITSUBISHI, FANUC
-  **The best tool layout among equivalent models**  
- For complicated shape parts  
- Shortened cycle time
-  **Expanded tool options**
-  **Specialized for high-precision parts**  
- Horizontal tool post  
- Dovetail structure



## TOOL Layout

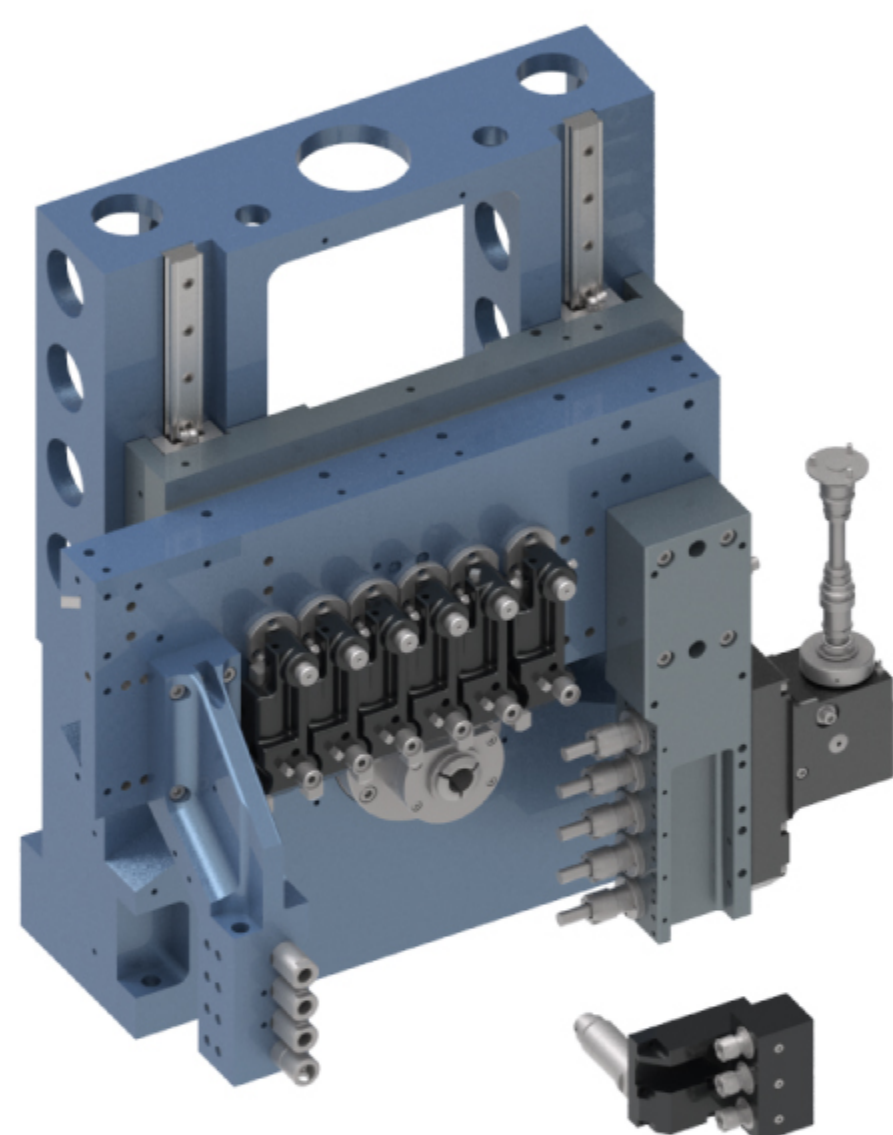
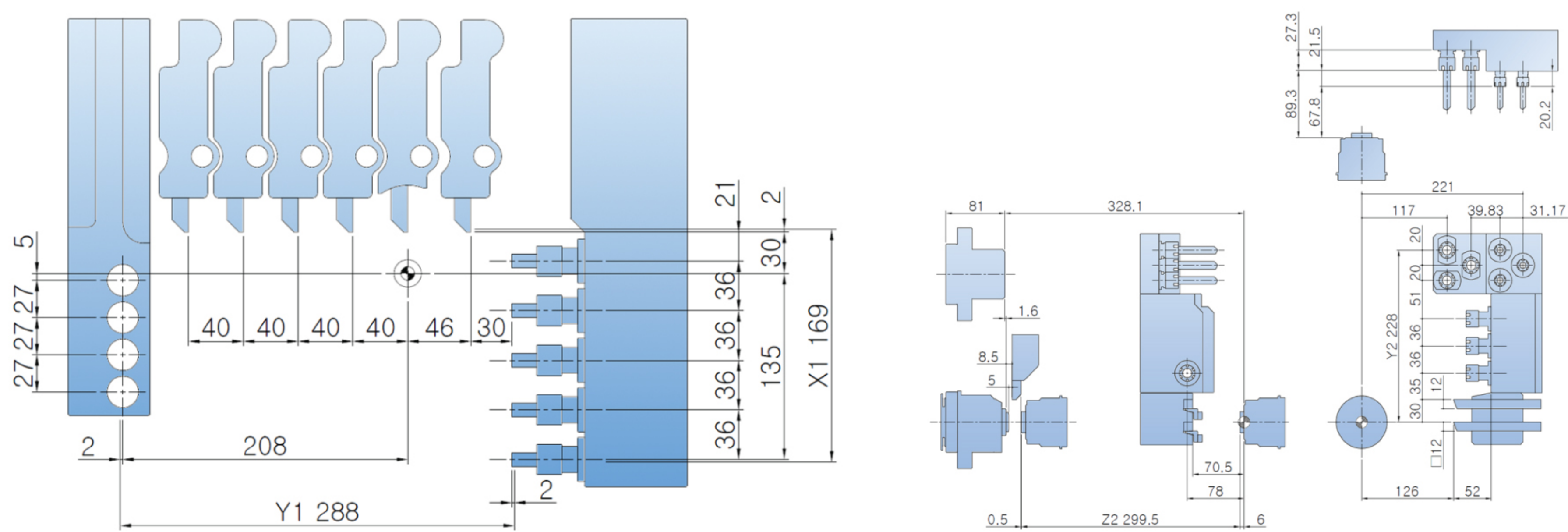

### \$1 (Main)

Tool name	Size	Equipment
O.D. Tool	□12.7 x 6	Standard
I.D. Tool	ER16 x 4	Standard
Cross Drill	ER16 x 5	Standard



3-spindle drilling unit  
(E3 unit - Option)  
for eccentric machining

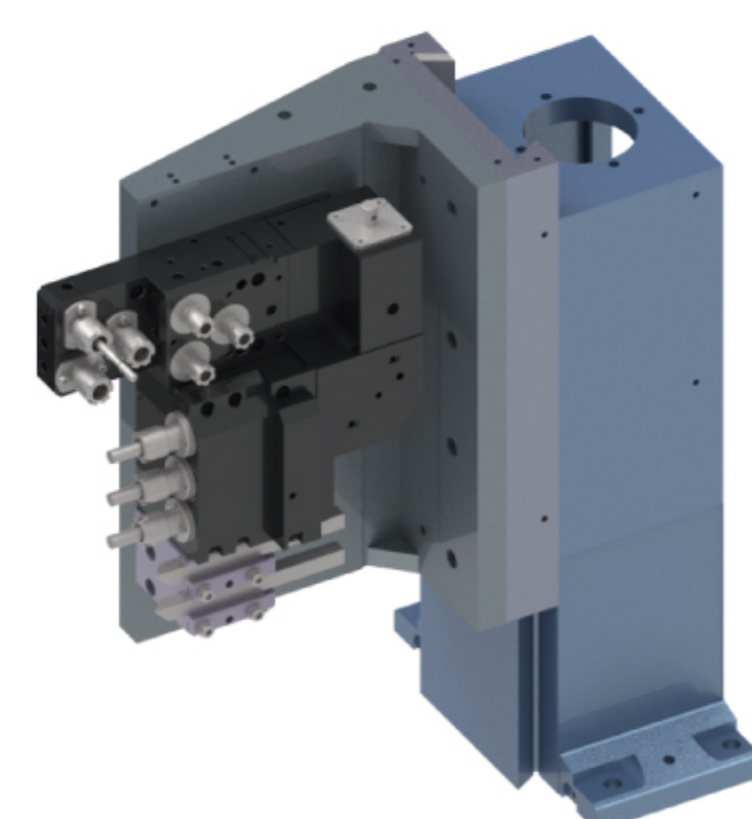

### \$2 (Sub)

Tool name	Size	Equipment
O.D. Tool	□12.7 x 2	Standard
I.D. Tool	ER16 x 3	Standard
Cross Drill	ER16 x 3	Standard
Eccentric Drill	ER11 x 3	Standard

## NN-20J3 Specifications

Content	Specification	Specification Value	Standard Accessories
Machining capacity	Max. machining diameter	Φ20mm	I.D. tool unit
	Max. machining length	200mm / 1chuck	Cross drill unit
	Max. parts unloading length	93mm	Manual pulse generator(MPG)37P
Spindle	Main spindle through-hole diameter	Φ23mm	Coolant unit
	Spindle rpm (Main/Sub)	Max. 10,000rpm	Rotary guide bush
	Sub spindle chucking diameter	Φ20mm	Tool holder
Tool	Max. number of tools	30	Drill holder
	Max. machining drill	Φ10mm	Main : Chuck sleeve /Spring/Spindle cap(1set)
	Max. machining tap	M10	Sub : Chuck sleeve /Spring/Spindle cap(1set)
Main	O.D. tool	6 (□12.7X150mm max)	Automatic power turn-off device
	I.D. tool	4 (ER16)	Automatic oiling device (level detector attached)
	Cross drill	5 (ER16)	Cutting oil device(Main/Sub)
	Cross drill rpm	Max. 6,000rpm	Coolant failure detector
SUB	O.D. tool	2 (□12.7X150mm max)	Overload detection function
	I.D. tool	3 (ER16)	Door interlock switch
	I.D. eccentric	3 (ER11)	Working light (LED)
	Cross drill	3 (ER16)	Parts conveyor
	Cross drill rpm	Max. 6,000rpm	Parts catcher
Feed	Rapid feed rate	X1,Y1,X2,Y2:28m/min Z1,Z2:30m/min	Levelling pad
	Min. command unit	0.0001mm(Mitsubishi) / 0.001mm(Fanuc)	Signal warning light - 3 stage
	C axis Min. command unit (Main, Sub)	0.0001°(Mitsubishi) / 0.001°(Fanuc)	Display language (CHN/ENG/FRA/GER/ITA/JPN/KOR/POL/RUS/SPA)
Motor	Main spindle motor	3.7/1.5kW(Mitsubishi) / 3.7/2.2kW(Fanuc)	<b>Optional Accessories</b>
	Cross drill motor	0.75kW(Mitsubishi) / 1.0kW(Fanuc)	Fanuc Oi-TF
	Sub spindle motor	3.7/1.5kW(Mitsubishi) / 3.7/2.2kW(Fanuc)	Long drill holder
	\$2 cross drill motor	0.75kW(Mitsubishi) / 1.0kW(Fanuc)	3-spindle drilling unit (E3 UNIT)
	Y1,Z1,X2,Z2 axis feed motor	0.5kW(Mitsubishi) / 1.4kW(Fanuc)	Fixed guide bush
	X1,Y2 axis feed motor	1.0kW(Mitsubishi) / 1.4kW(Fanuc)	Tap breakage detector (Main, Sub)
	Coolant pump (Main, Sub)	0.25kW X 2	Tool presetter
	Lubricant pump	0.003kW	Tool air blow
Dimensions and etc.	Main spindle center height	1,010mm	Rear ejection unit (Φ17mm or less)
	Input power capacity	17KVA	Spindle tube liner for small part
	Air pressure, flow rate	0.6MPa.40L/min	Large-sized lubricant pump 1.8ℓ
	Coolant tank	160L	Chip conveyor & Chip box
	WxDxH	2,390x1,500x1,855 mm	Medium / High pressure coolant
	Weight (Options included)	2,700kg	Automatic fire extinguisher
NC	NC (MITSUBISHI / FANUC)	M70V Type A(Mitsubishi) / Oi TF(Fanuc)	Oil mist collector
	NC display	10.4 Color TFT LCD	Custom colors
	Memory capacity	500KB(Mitsubishi) / 1MB(Fanuc)	Tooling
	Number of tool offset	80sets(Mitsubishi) / 128sets(Fanuc)	
	Background edit function		
	C axis function (Main, Sub spindle)		
	User macro function		
	Nose R compensation		
	Corner chamfering /Corner rounding		
	Fixed cycle		
	Complex fixed cycle		
	Geometric commands		
	Controller manual		
	Serial in / Output interface		
CF card / USB interface			

## FLOOR Layout

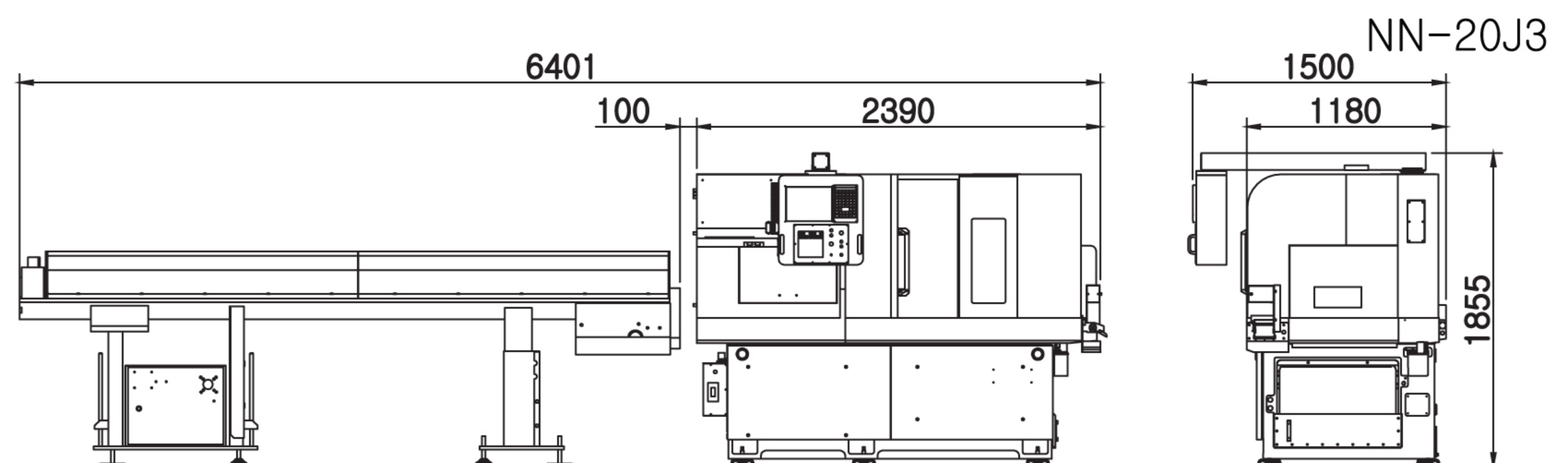



## NN-20J3XB Specifications

Content	Specification	Specification Value	Standard Accessories	
Machining capacity	Max. machining diameter	Φ20mm	I.D. tool unit	
	Max. machining length	200mm / 1chuck	Cross drill unit	
	Max. parts unloading length	93mm	Manual pulse generator(MPG)37P	
Spindle	Main spindle through-hole diameter	Φ23mm	Coolant unit	
	Spindle rpm (Main/Sub)	Max. 10,000rpm	Rotary guide bush	
	Sub spindle chucking diameter	Φ20mm	Tool holder	
Tool	Max. number of tools	30 (OP:28)	Drill holder	
	Max. machining drill	Φ10mm	Main : Chuck sleeve /Spring/Spindle cap(1set)	
	Max. machining tap	M10	Sub : Chuck sleeve /Spring/Spindle cap(1set)	
Main	O.D. tool	5 (□12.7X150mm max)	Automatic power turn-off device	
	I.D. tool	4 (ER16)	Automatic oiling device (level detector attached)	
	Cross drill	5 (ER16)	Cutting oil device (Main/Sub)	
	Cross drill rpm	Max. 6,000rpm	Coolant failure detector (Main/Sub)	
SUB	O.D. tool	2 (□12.7X150mm max)	Overload detection function	
	I.D. tool	3 (ER16)	Door interlock switch	
	I.D. eccentric	3 (ER11)	Working light (LED)	
	Cross drill	3 (ER16)	4(ER16) : OP	Parts conveyor
	Cross drill rpm	Max. 6,000rpm	Parts catcher	
Feed	Rapid feed rate	X1,Y1,X2,Y2:28m/min Z1,Z2:30m/min	Levelling pad	
	Min. command unit	0.0001mm	Signal warning light - 3 stage	
	C axis Min. command unit (Main, Sub)	0.0001°	Cut-off breakage detector	
Motor	Main spindle motor	3.7/1.5kW	Display language (CHN/ENG/FRA/GER/ITA/JPN/KOR/POL/RUS/SPA)	
	Cross drill motor	1.5kW	<b>Optional Accessories</b>	
	Sub spindle motor	3.7/1.5kW	Long drill holder	
	\$2 cross drill motor	1.5kW	Fixed guide bush	
	Y1,Z1,X2,Z2 feed axis motor	0.5kW	Tap breakage detector (Main, Sub)	
	X1,Y2 axis feed motor	1.0kW	Tool presetter	
	Coolant pump (Main, Sub)	0.25kW X 2	Tool air blow	
	Lubricant pump	0.003kW	Rear ejection unit (Φ17mm or less)	
Dimensions and etc.	Main spindle center height	1,010mm	Spindle tube liner for small part	
	Input power capacity	14KVA	Large-sized lubricant pump 1.8ℓ	
	Air pressure, flow rate	0.6MPa.40L/min	Chip conveyor & Chip box	
	Coolant tank	160L	Medium / High pressure coolant	
	WxDxH	2,365x1,478x2,005 mm	Automatic fire extinguisher	
	Weight (Options included)	2,800kg	Oil mist collector	
NC	MITSUBISHI NC	M70V TYPE A (※B2 axis applied: M720)	Custom colors	
	NC display	10.4 Color TFT LCD	Tooling	
	Memory capacity	500KB(B2 axis applied : 2,000KB)		
	Number of tool offset	80sets(B2 axis applied : 80sets)		
	Background edit function			
	C axis function (Main, Sub spindle)			
	User macro function			
	Nose R compensation			
	Corner chamfering /Corner rounding			
	Fixed cycle			
	Complex fixed cycle			
	Geometric commands			
	Controller manual			
	Serial in / Output interface			
CF card / USB interface				

## FLOOR Layout

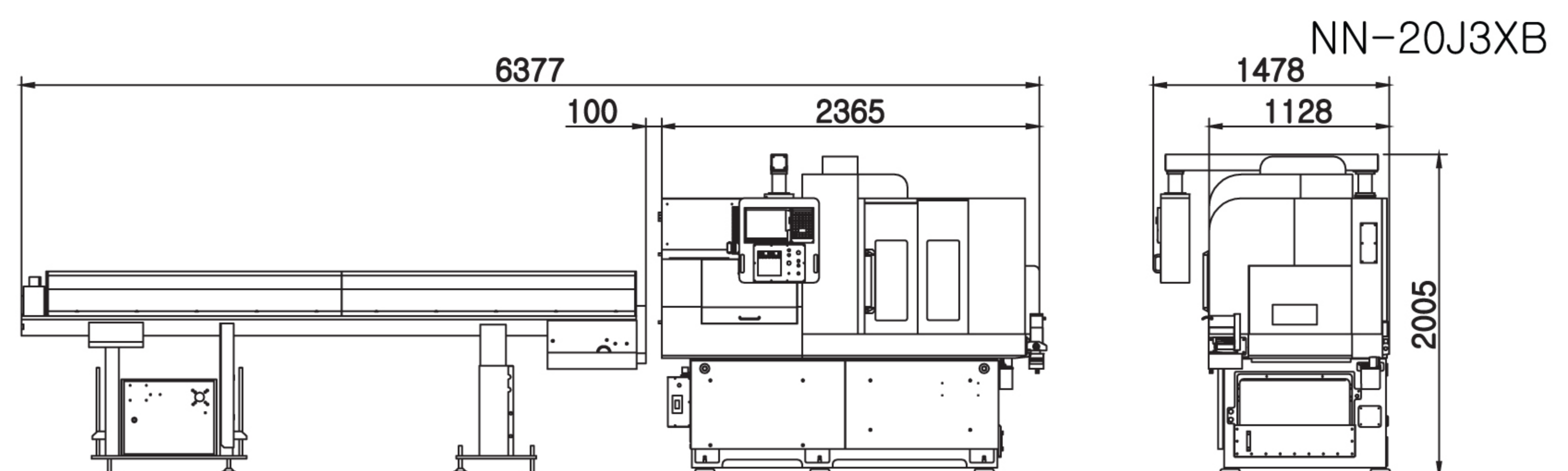

# NN-32UB8

**The best selling model**  
 - Horizontal tool post  
 - Dovetail structure

**Efficient tool layout**  
 - Shortened cycle time

**High efficiency, reasonable price**



## TOOL Layout

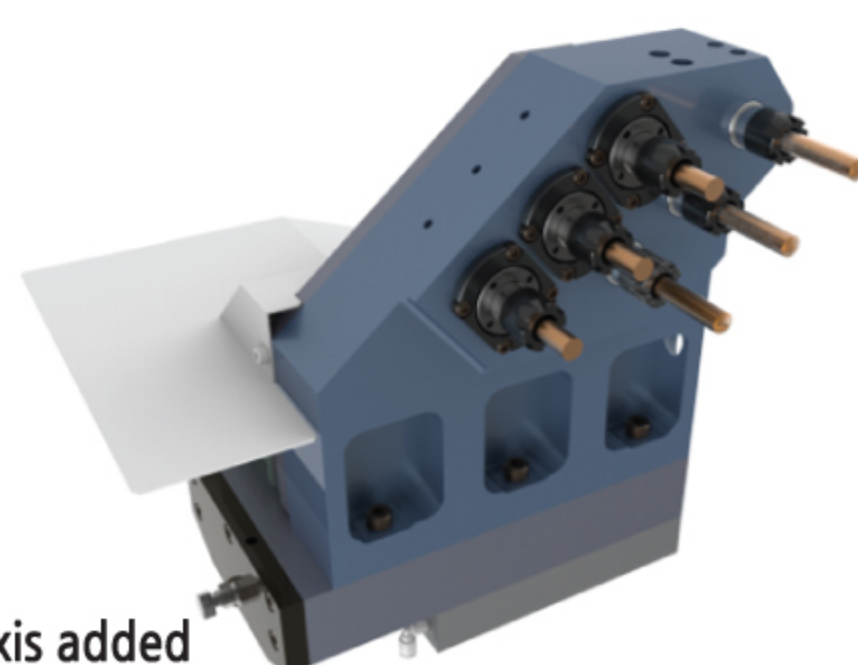
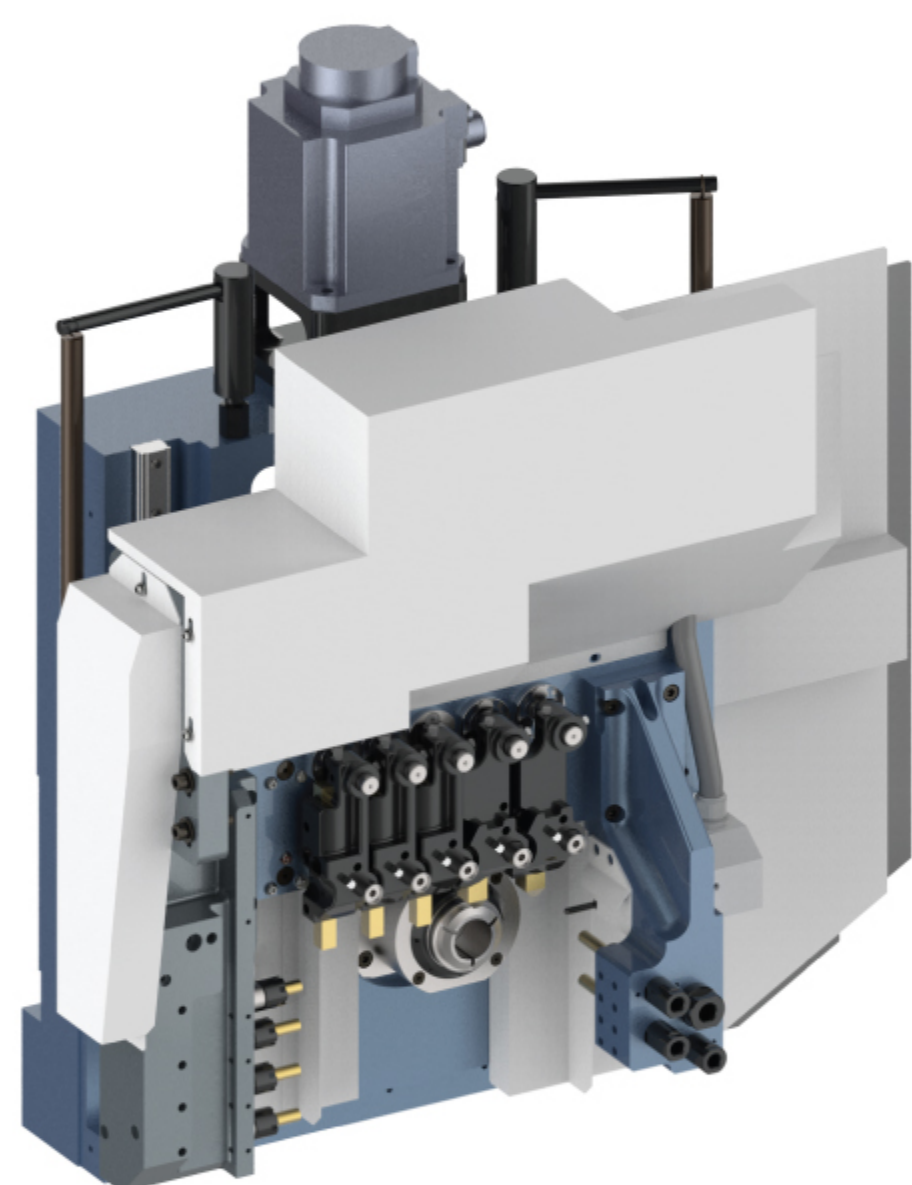
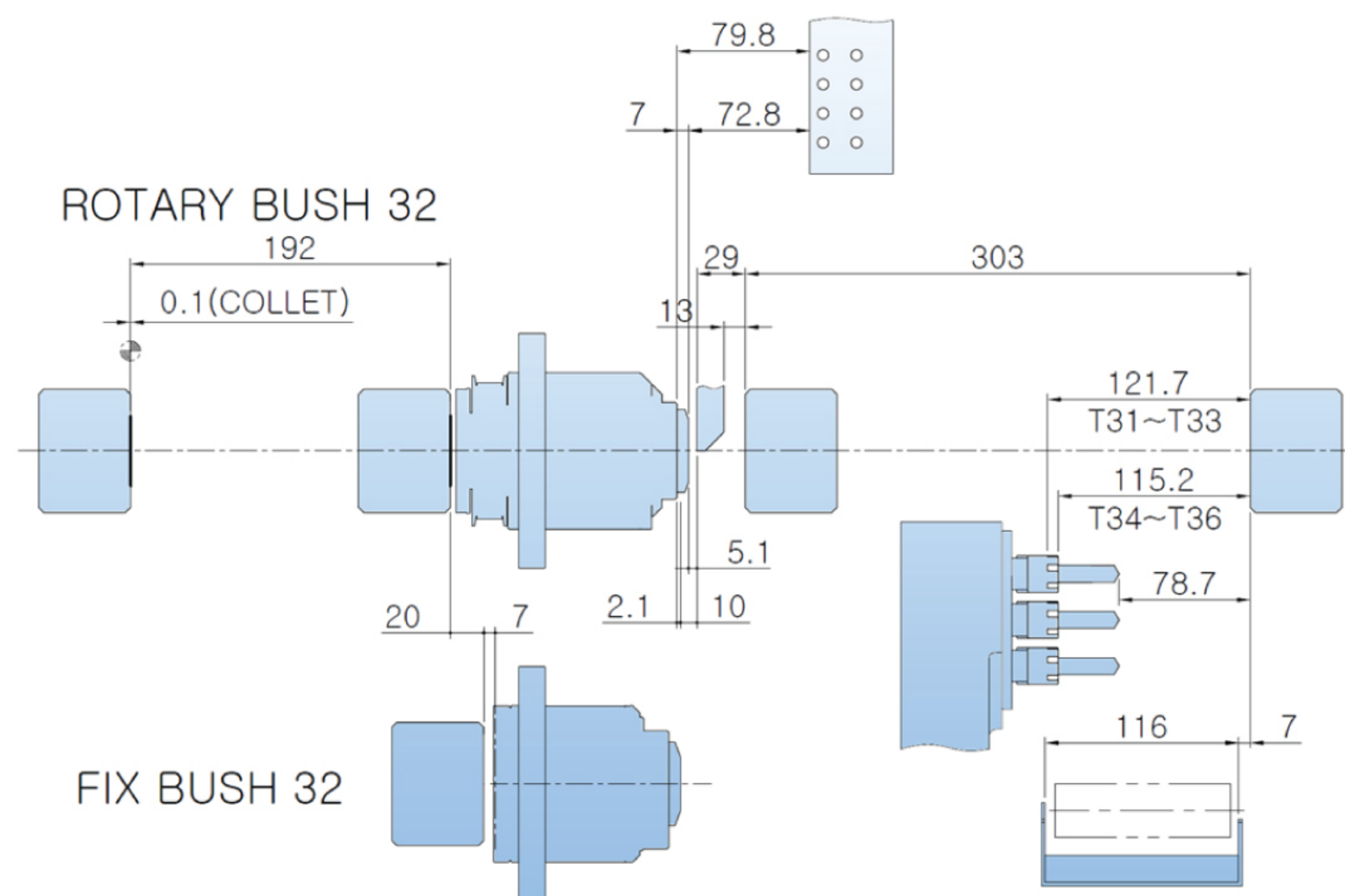
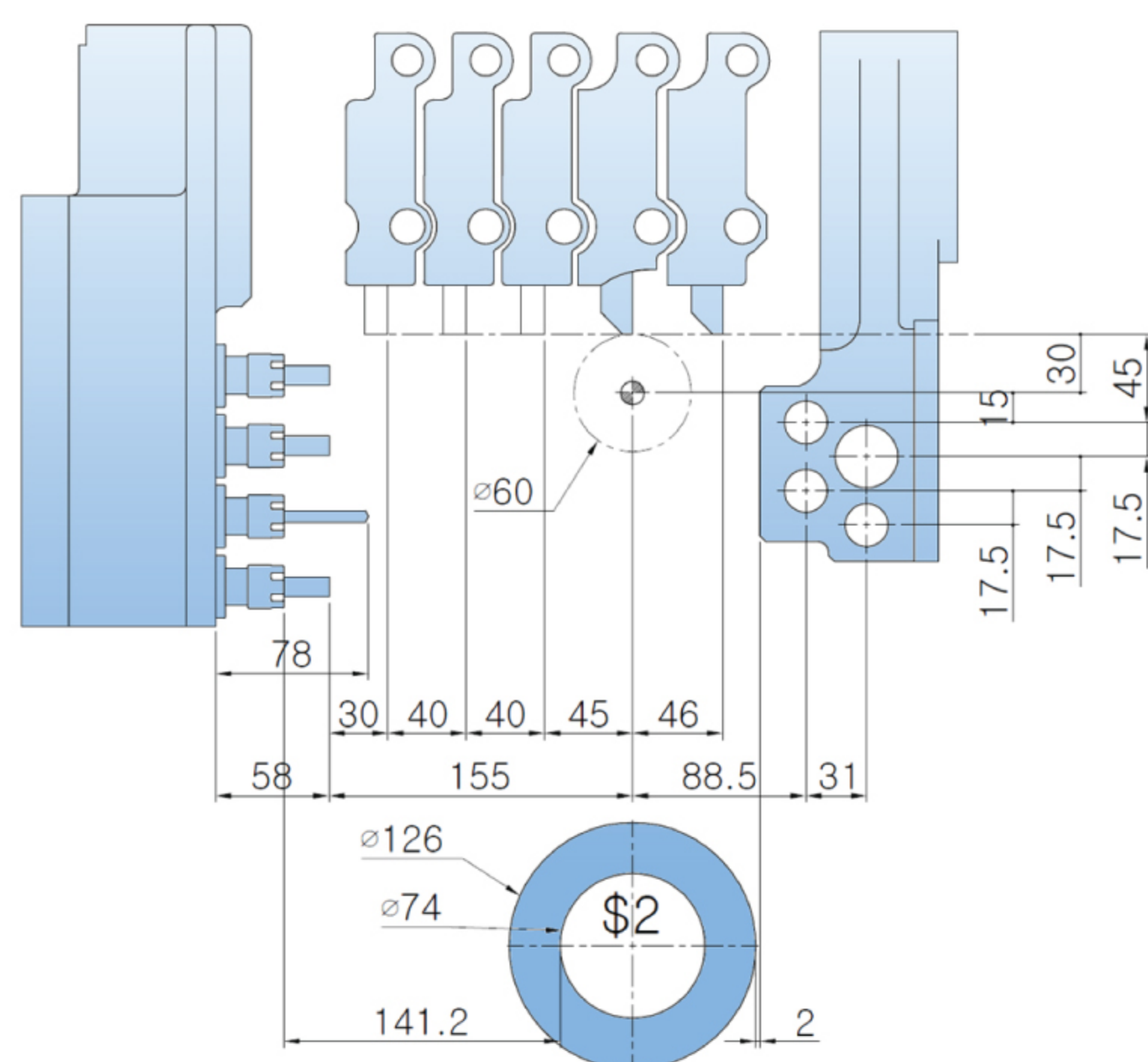

K2 type  
Hydraulic feed axis added

### \$1 (Main)

Tool name	Standard Size	Equipment
O.D. Tool	$\square 12.7 \times 3 + \square 16 \times 2$	Standard
I.D. Tool	ER16x3 + ER20x1	Standard
Cross Drill	ER16 x 4	Standard

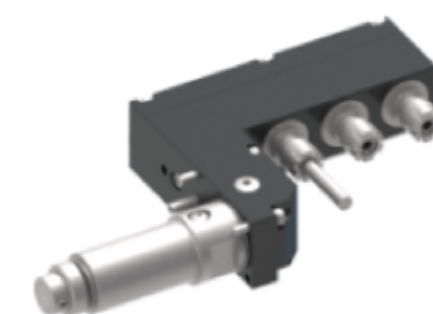

3-spindle drilling unit  
(E3 unit - Option)  
for eccentric machining

### \$2 (Sub)

Tool name	K2 type (STD)
I.D. Tool	ER16 x 3
I.D. Rotary Tool	ER16 x 3

## NN-32UB8 Specifications

Content	Specification	Specification Value	Standard Accessories
		32UB8K2	
Machining capacity	Max. machining diameter	Φ32mm	I.D. tool unit
	Max. machining length	190mm / 1chuck	Cross drill unit
	Max. parts unloading length	93mm(N:80mm)	Manual pulse generator(MPG)37P
Spindle	Main spindle through-hole diameter	Φ34mm	Main coolant unit
	Spindle rpm (Main/Sub)	Max.8,000rpm/6,000rpm	Rotary guide bush
	Sub spindle chucking diameter	Φ32mm	Tool holder
Tool	Max. number of tools	23	Drill holder
	Max. machining drill	Φ10mm	Main : Chuck sleeve /Spring/Spindle cap(1set)
	Max. machining tap	M8	Sub : Chuck sleeve /Spring/Spindle cap(1set)
Main	O.D. tool	5 (□12.7x3+□16X2X150mm max)	Automatic power turn-off device
	I.D. tool	4 (ER16X3+ER20X1)	Automatic oiling device (level detector attached)
	Cross drill	4 (ER16)	Cutting oil device
	Cross drill rpm	Max. 6,000rpm	Coolant failure detector
SUB	I.D. tool	3 (ER16)	Overload detection function
	I.D. rotary tool	3 (ER16)	Door interlock switch
Feed	Rapid feed rate	X1, X2, Y1 : 30/min Z1, Z2, : 28m/min	Working light (LED)
	Min. command unit	0.0001mm(Mitsubishi) / 0.001mm(Fanuc)	Parts conveyor
	C axis Min. command unit (Main, Sub)	0.0001°(Mitsubishi) / 0.001°(Fanuc)	Levelling pad
Motor	Main spindle motor	5.5/3.7kW(Mitsubishi) / 5.5/3.7kW(Fanuc)	Signal warning light - 3 stage
	Cross drill motor	1.5kW(Mitsubishi) / 1.0kW(Fanuc)	Display language (CHN/ENG/FRA/GER/ITA/JPN/KOR/POL/RUS/SPA)
	Sub spindle motor	3.7/1.5kW(Mitsubishi) / 3.7/2.2kW(Fanuc)	<b>Optional Accessories</b>
	\$2 rotary motor	0.9kW(Mitsubishi) / 1.0kW(Fanuc)	5-spindle cross drilling unit
	Y1,X2,Z2 axis feed motor	0.5kW(Mitsubishi) / 1.4kW(Fanuc)	3-spindle drilling unit (E3 Unit)
	X1,Z1 axis feed motor	1.0kW(Mitsubishi)/ 1.4kW(Fanuc)	Long drill holder
	Coolant pump (Main, Sub)	0.25kW	Fixed guide bush
	Lubricant pump	0.003kW	Tap breakage detector
Dimensions and etc.	Main spindle center height	1,000mm	Tool presetter
	Input power capacity	12KVA	Tool air blow
	Air pressure, flow rate	0.6MPa.20L/min	Rear ejection unit (Φ24 or less)
	Coolant tank	110L	Spindle tube liner for small part
	WxDxH	2,330 x 1,047 x 1,676mm	Large-sized lubricant pump 1.8ℓ
	Weight (Options included)	2,350kg	Chip conveyor & Chip box
NC	NC(MITSUBISHI/FANUC)	M70V Type A / Oi TF (Fanuc)	Medium / High pressure coolant
	NC display	8.4 Color TFT LCD	Automatic fire extinguisher
	Memory capacity	500KB(Mitsubishi) / 1MB(Fanuc)	Oil mist collector
	Number of tool offset	80sets(Mitsubishi) / 128sets(Fanuc)	Custom colors
	Background edit function		Tooling
	C axis function (Main, Sub spindle)		
	User macro function		
	Nose R compensation		
	Corner chamfering /Corner rounding		
	Fixed cycle		
	Complex fixed cycle		
	Geometric commands		
	Controller manual		
Serial in / Output interface			
CF card / USB interface			

## FLOOR Layout

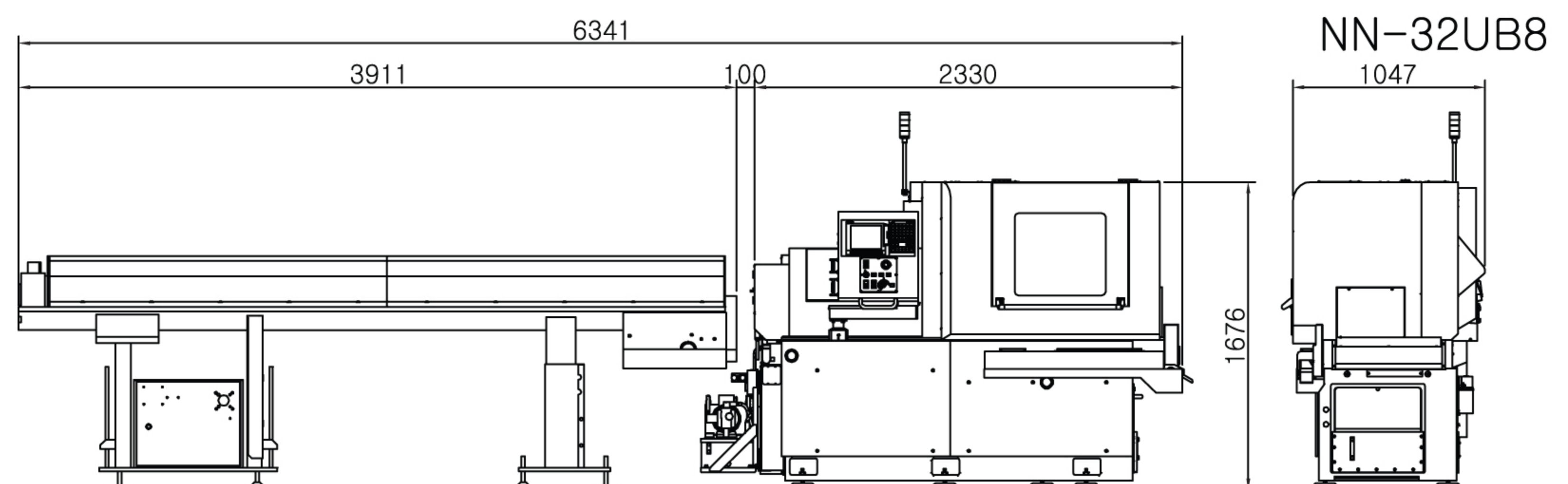

# NN-32YB3

-  **Competitive tooling capacity**  
- Maximized number of tools (sub tool post)
-  **The best selling model**  
- Horizontal tool post  
- Dovetail structure
-  **Specialized for complicated shape parts**  
- Expanded tool options
-  **Minimized heat deformation and vibration**  
- Integrated casting bed



## TOOL Layout

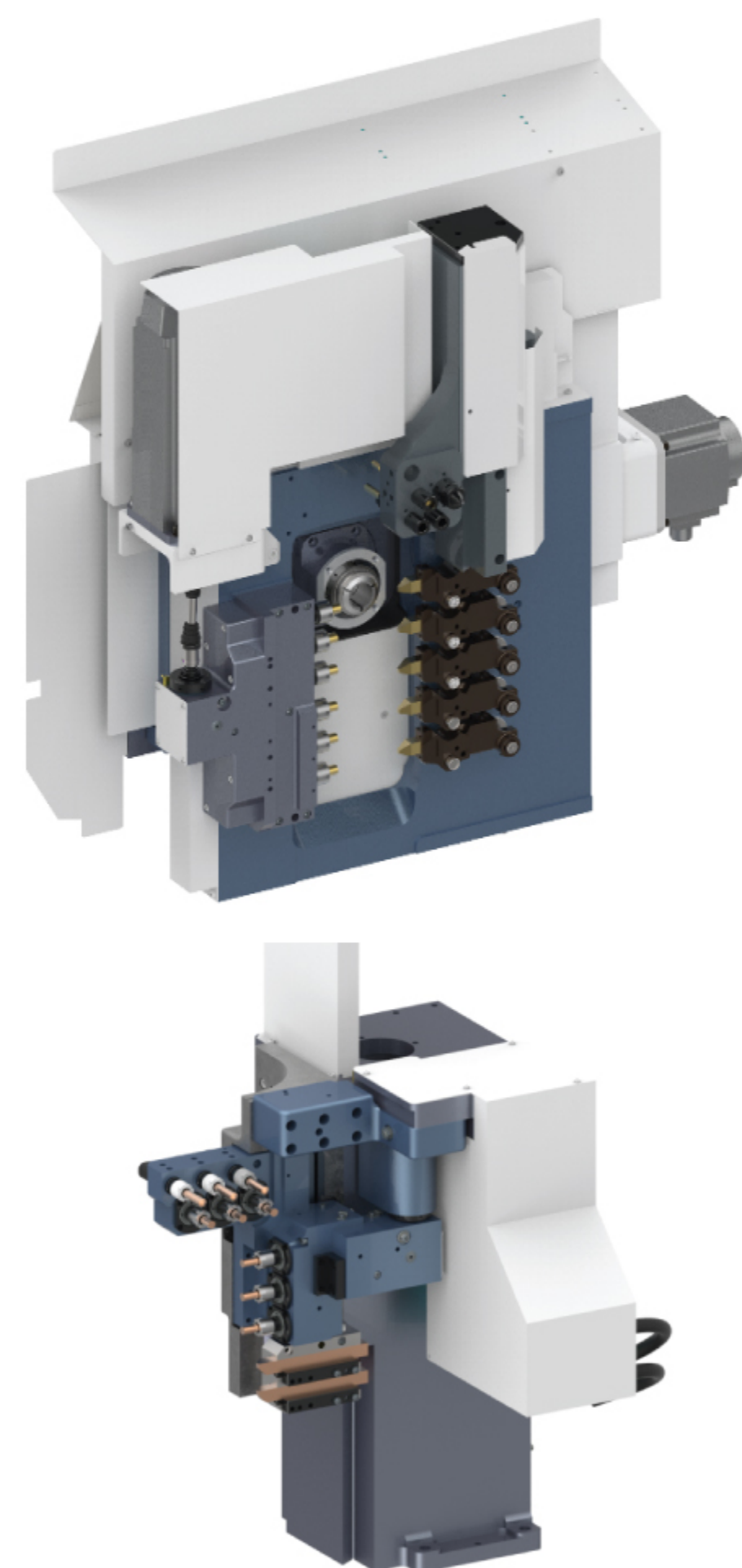
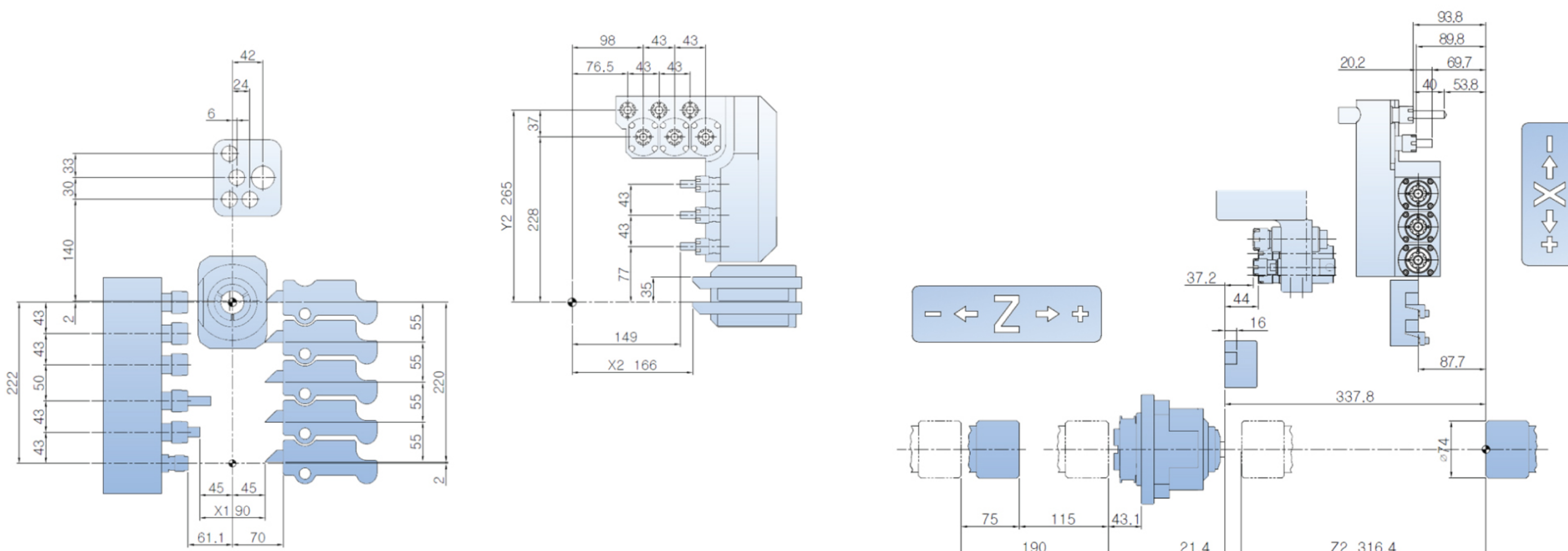

### \$1 (Main)

Tool name	Size	Equipment
O.D. Tool	□16.0 x 5	Standard
I.D. Tool	ER-20 x 1/ER16 x 3	Standard
Cross Drill	ER20 x 6	Standard

### \$2 (Sub)

Tool name	Size	Equipment
O.D. Tool	□16.0 x 2	Standard
I.D. Tool	ER16 x 3	Standard
Cross Drill	ER16 x 3	Standard
Eccentric Drill	ER16 x 3	Standard

## NN-32YB3 Specifications

Content	Specification	Specification Value	Standard Accessories
Machining capacity	Max. machining diameter	Φ32mm	I.D. tool unit
	Max. machining length	190mm /1chuck	Cross drill unit
	Max. parts unloading length	93mm	Manual pulse generator(MPG)37P
Spindle	Main spindle through-hole diameter	Φ37mm	Coolant unit
	Spindle rpm (Main/Sub)	Max. 8,000rpm	Rotary guide bush
	Sub spindle chucking diameter	Φ32mm	Tool holder
Tool	Max. number of tools	30	Drill holder
	Max. machining drill	Φ13mm	Main : Chuck sleeve /Spring/Spindle cap(1set)
	Max. machining tap	M10	Sub : Chuck sleeve /Spring/Spindle cap(1set)
Main	O.D. tool	5 (□16X150mm max)	Automatic power turn-off device
	I.D. tool	4 (ER16x3 + ER20x1)	Automatic oiling device (level detector attached)
	Cross drill	6 (ER20x6)	Cutting oil device (Main/Sub)
	Cross drill rpm	Max. 6,000rpm	Coolant failure detector
SUB	O.D. tool	2 (□16X150mm max)	Overload detection function
	I.D. tool	3 (ER16)	Door interlock switch
	I.D. eccentric	3 (ER16)	Working light (LED)
	Cross drill	3 (ER16)	Parts conveyor
	Cross drill rpm	Max. 6,000rpm	Levelling pad
Feed	Rapid feed rate	X1 : 20/min X2 : 25m/min Z1,Z2,Y1,Y2 : 28m/min	Signal warning light – 3 stage
	Min. command unit	0.0001mm(Mitsubishi) / 0.001mm(Fanuc)	Display language (CHN/ENG/FRA/GER/ITA/JPN/KOR/POL/RUS/SPA)
	C axis Min. command unit (Main, Sub)	0.0001°(Mitsubishi) / 0.001°(Fanuc)	<b>Optional Accessories</b>
Motor	Main spindle motor	5.5/3.7Kw(Mitsubishi) / 7.5/5.5kW(Fanuc)	Fanuc Oi-TF
	Cross drill motor	1.5kW(Mitsubishi) / 1.0kW(Fanuc)	E3 UNIT
	Sub spindle motor	3.7/1.5kW(Mitsubishi)/ 5.5/2.2kW(Fanuc)	7-spindle cross drilling unit
	Φ2 cross drill motor	1.5kW(Mitsubishi) / 1.0kW(Fanuc)	O.D. tool post (6 holes)
	X1.Y1,Z1,X2.Y2.Z2 axis feed motor	1.0kW(Mitsubishi) / 1.4kW(Fanuc)	Long drill holder
	Coolant pump (Main, Sub)	0.25kW x 2	Fixed guide bush
	Lubricant pump	0.003kW	Tap breakage detector
Dimensions and etc.	Main spindle center height	1,000mm	Tool presetter
	Input power capacity	15KVA	Tool air blow
	Air pressure, flow rate	0.6MPa. 20L/min	Rear ejection unit (Φ24mm or less)
	Coolant tank	100L	Spindle tube liner for small part
	WxDxH	2,270x1,425x1,825 mm	Large-sized lubricant pump 1.8ℓ
	Weight (Options included)	3,030kg	Chip conveyor & Chip box
NC	NC(MITSUBISHI/FANUC)	M70V Type A / Oi TF (Fanuc)	Medium / High pressure coolant
	NC display	10.4 Color TFT LCD	Automatic fire extinguisher
	Memory capacity	500KB(Mitsubishi) / 1MB(Fanuc)	Oil mist collector
	Number of tool offset	80sets(Mitsubishi) / 128sets(Fanuc)	Custom colors
	Background edit function		Tooling
	C axis function (Main, Sub spindle)		
	User macro function		
	Nose R compensation		
	Corner chamfering /Corner rounding		
	Fixed cycle		
	Complex fixed cycle		
	Geometric commands		
	Controller manual		
Serial in / Output interface			
CF card / USB interface			

## FLOOR Layout

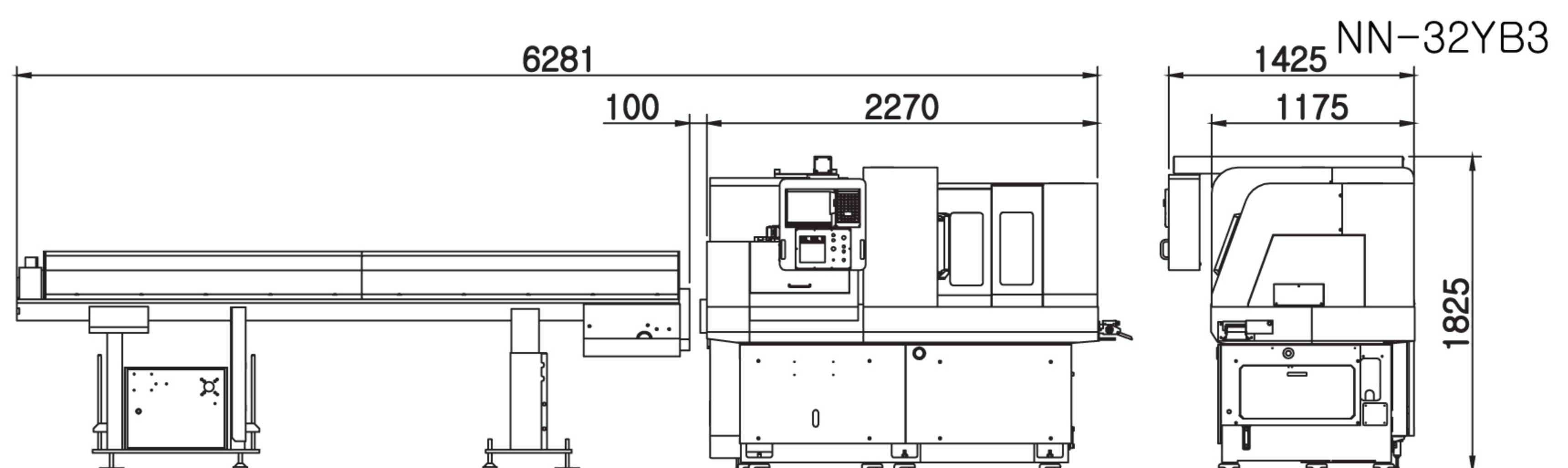

# NN-32YB3XB

-  **B axis control (0-135° rotation)**  
- Drill, tapping, end-mill
-  **The best selling model**  
- Horizontal tool post  
- Dovetail structure
-  **Specialized for complicated shape parts**  
- Expanded tool options
-  **Minimized heat deformation and vibration**  
- Integrated casting bed



## TOOL Layout

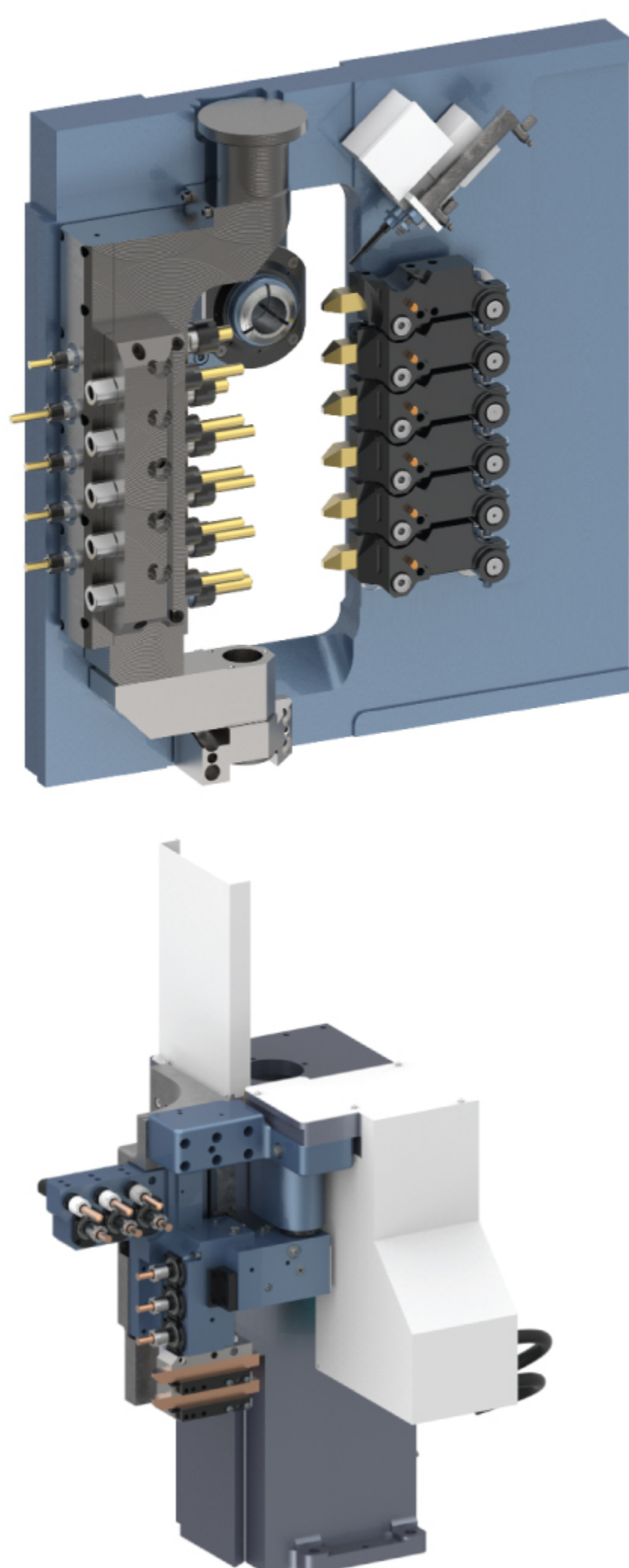
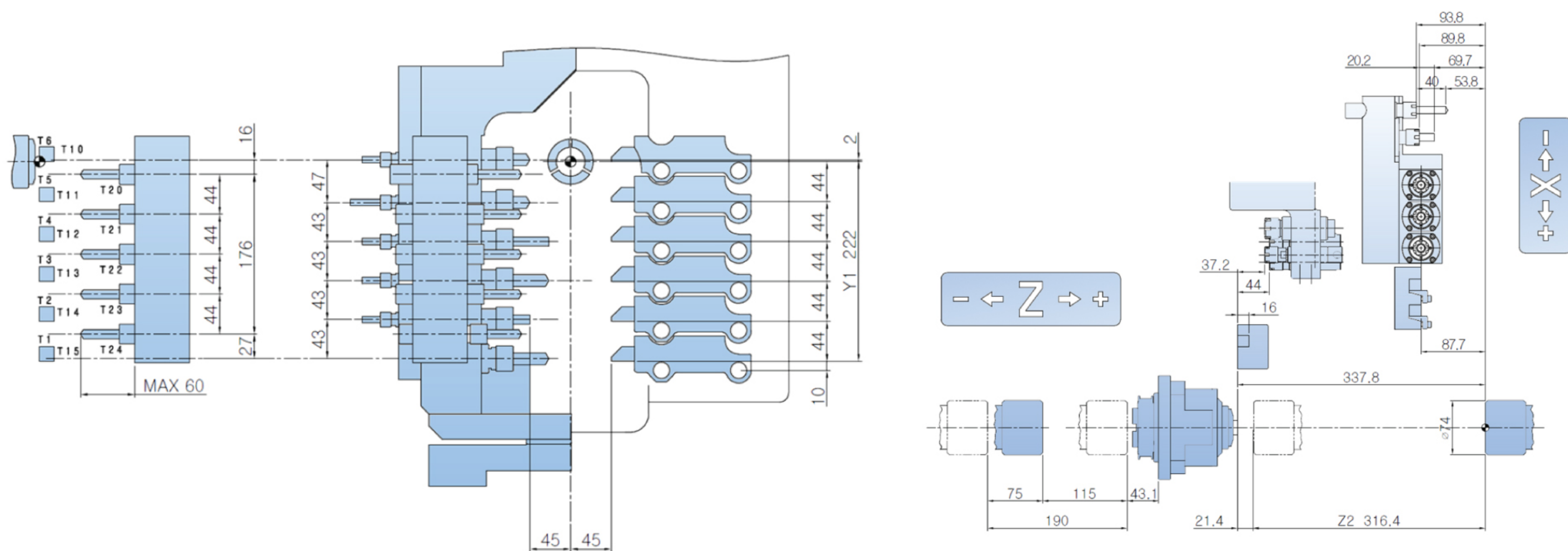

### \$1 (Main)

Tool name	Size	Equipment
O.D. Tool	□ 16.0 x 6	Standard
I.D. Tool	ER16 x 5/ER20 x 1	Standard
Cross Drill	ER20 x 5/ER11 x 5	Standard

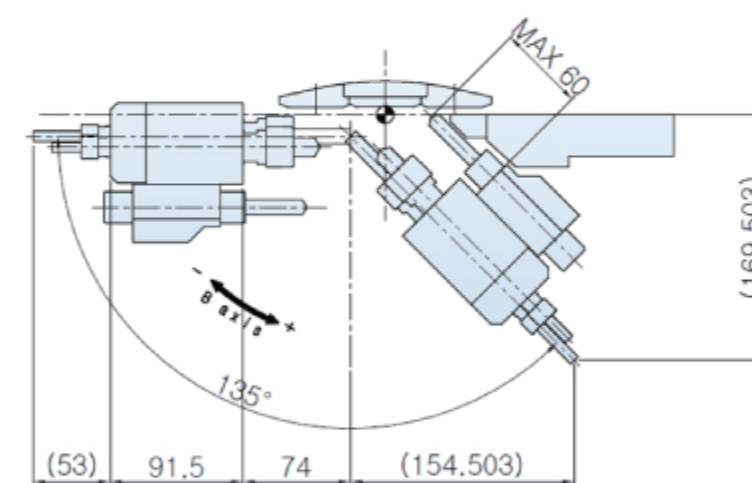

### B1-axis control (Standard)

0~135° rotation  
Cross / Eccentric / hole on angled surface 12EA  
(Rigidity attained by top and bottom supporting structure)

### \$2 (Sub)

Tool name	Size	Equipment
O.D. Tool	□ 16.0 x 2	Standard
I.D. Tool	ER16 x 3	Standard
Cross Drill	ER16 x 3	Standard
Eccentric Drill	ER16 x 3	Standard

No.of sub-side tool: 11

Improved work efficiency with more number of sub-side tools

## NN-32YB3XB Specifications

Content	Specification	Specification Value	Standard Accessories
Machining capacity	Max. machining diameter	Φ32mm	I.D. tool unit
	Max. machining length	190mm /1chuck	Cross drill unit
	Max. parts unloading length	93mm	Manual pulse generator(MPG)37P
Spindle	Main spindle through-hole diameter	Φ37mm	Coolant unit
	Spindle rpm (Main/Sub)	Max. 8,000rpm	Rotary guide bush
	Sub spindle chucking diameter	Φ32mm	Tool holder
	Max. number of tools	39	Drill holder
	Max. machining drill	Φ13mm	Main : Chuck sleeve /Spring/Spindle cap(1set)
	Max. machining tap	M10	Sub : Chuck sleeve /Spring/Spindle cap(1set)
Main	O.D. tool	6 (□16X150mm max)	Automatic power turn-off device
	I.D. tool	6(ER16x5+OP5tools) + (ER20x1+OP1tools)	Automatic oiling device (level detector attached)
	Cross drill (B axis)	10 (ER20x5) + (ER11x5)	Cutting oil device (Main/Sub)
	Cross drill rpm	Max. 6,000rpm	Coolant failure detector(Main/Sub)
SUB	O.D. tool	2 (□16X150mm max)	Overload detection function
	I.D. tool	3 (ER16)	Door interlock switch
	I.D. eccentric	3 (ER16)	Working light (LED)
	Cross drill	3 (ER16)	Parts conveyor
	Cross drill rpm	Max. 6,000rpm	Levelling pad
Feed	Rapid feed rate	X1 : 20/min X2 : 25m/min Z1,Z2,Y1,Y2 : 28m/min	Signal warning light - 3 stage
	Min. command unit	0.0001mm	Display language (CHN/ENG/FRA/GER/ITA/JPN/KOR/POL/RUS/SPA)
	C axis Min. command unit (Main, Sub)	0.0001°	<b>Optional Accessories</b>
Motor	Main spindle motor	5.5/3.7kW	Long drill holder
	Cross drill motor	1.5kW	Fixed guide bush
	Sub spindle motor	3.7/1.5kW	Tap breakage detector (Main, Sub)
	\$2 cross drill motor	1.5kW	Tool presetter
	X1.Y1,Z1,X2.Y2.Z2 axis feed motor	1.0kW	Tool air blow
	Coolant pump (Main, Sub)	0.25kW x 2	Rear ejection unit (Φ24mm or less)
	Lubricant pump	0.003kW	Spindle tube liner for small part
Dimensions and etc.	Main spindle center height	1,000mm	Large-sized lubricant pump 1.8ℓ
	Input power capacity	15KVA	Chip conveyor & Chip box
	Air pressure, flow rate	0.6MPa. 20L/min	Medium / High pressure coolant
	Coolant tank	100L	Automatic fire extinguisher
	WxDxH	2,278 x 1,656 x 1,990 mm	Oil mist collector
	Weight (Options included)	3,050kg	Custom colors
NC	MITSUBISHI NC	M70V Type A	Tooling
	NC display	10.4 Color TFT LCD	
	Memory capacity	500KB	
	Number of tool offset	80sets	
	Background edit function		
	C axis function (Main, Sub spindle)		
	User macro function		
	Nose R compensation		
	Corner chamfering /Corner rounding		
	Fixed cycle		
	Complex fixed cycle		
	Geometric commands		
	Controller manual		
	Serial in / Output interface		
CF card / USB interface			

## FLOOR Layout

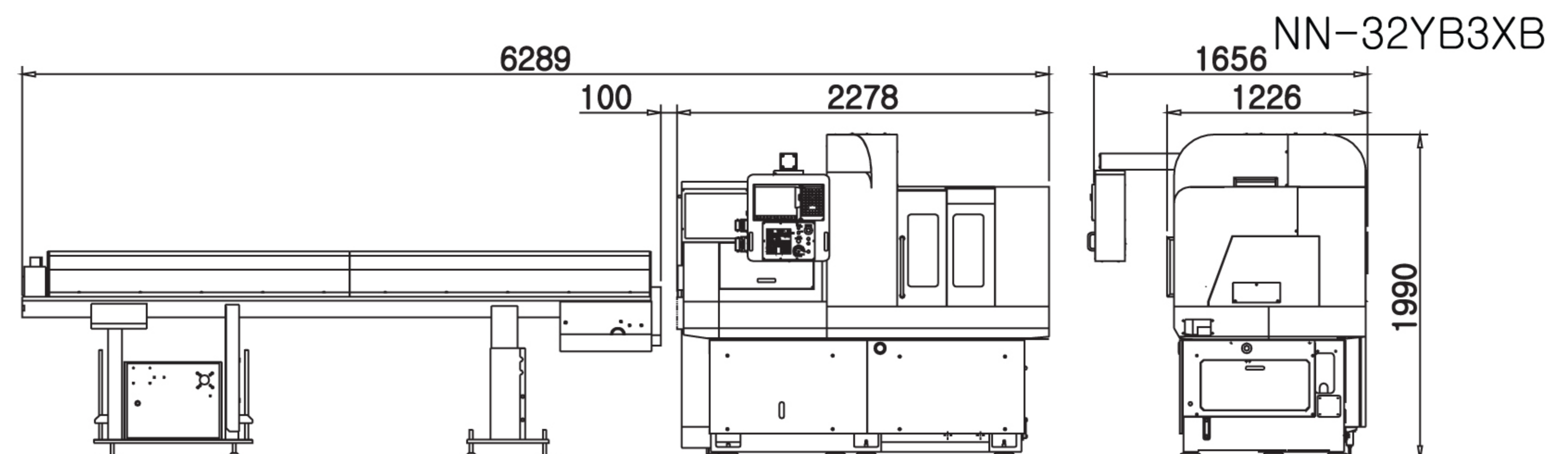

# NN-38UB8

 The latest NC "MITSUBISHI M80"

 **New model**  
 - For complicated shape parts  
 - Shortened cycle time  
 - Long drill

 **Specialized for high-precision parts**  
 - Horizontal tool post  
 - Dovetail structure



## TOOL Layout

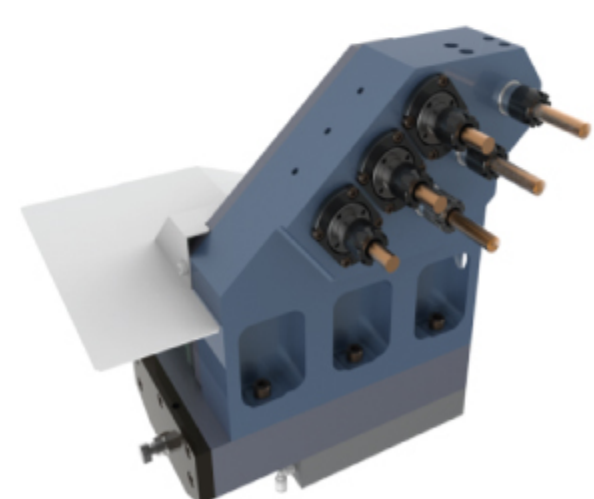
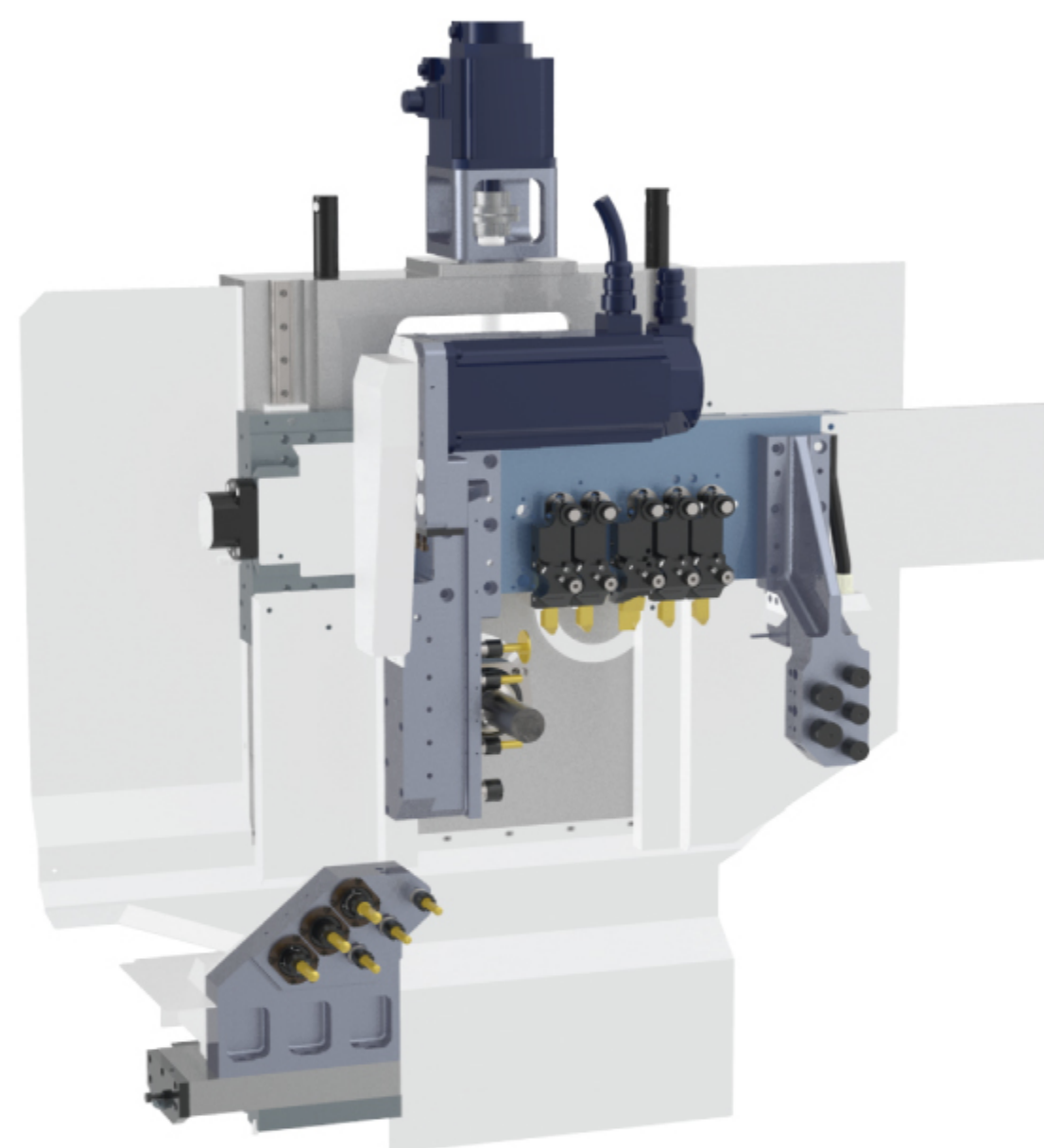
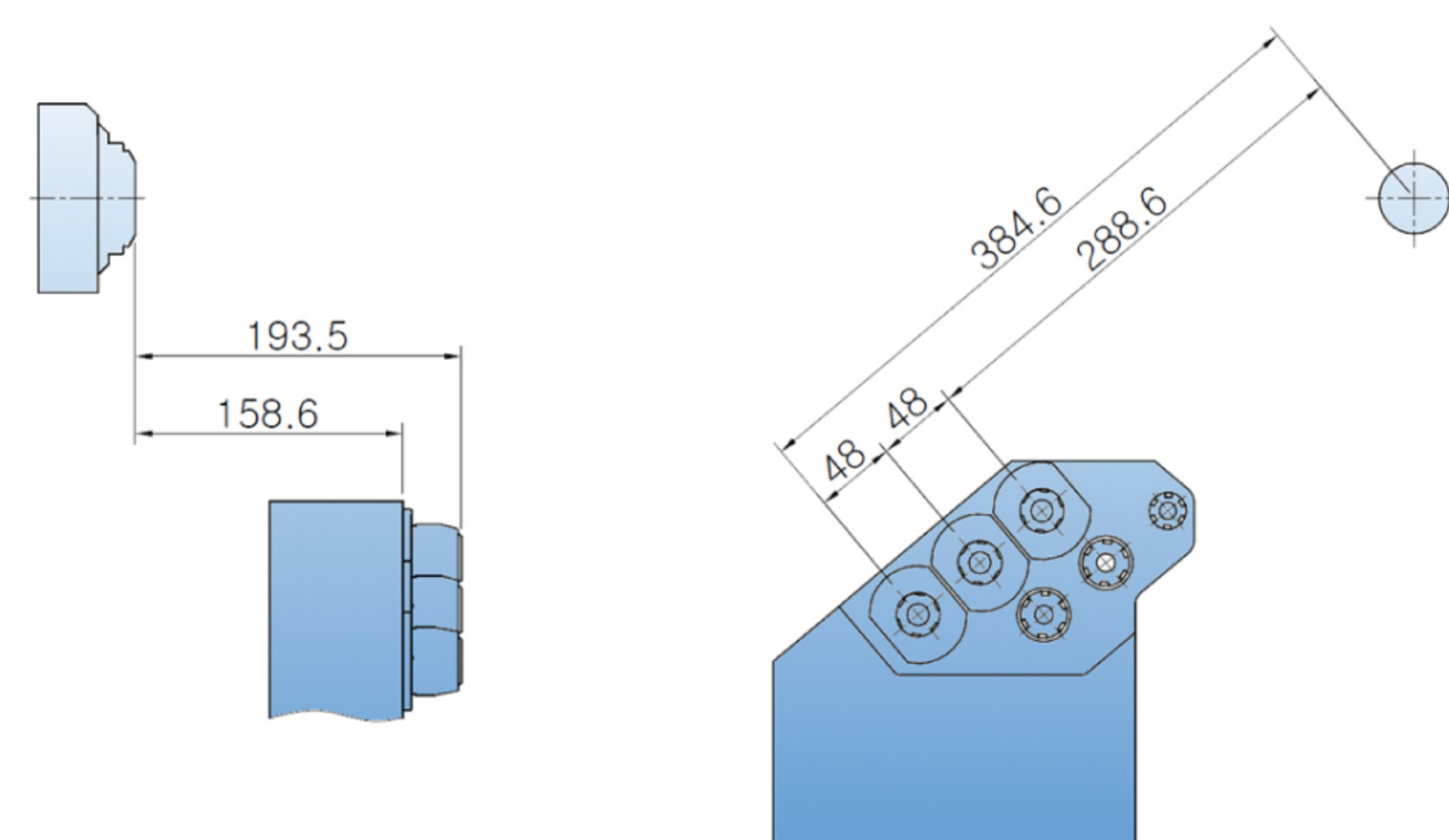
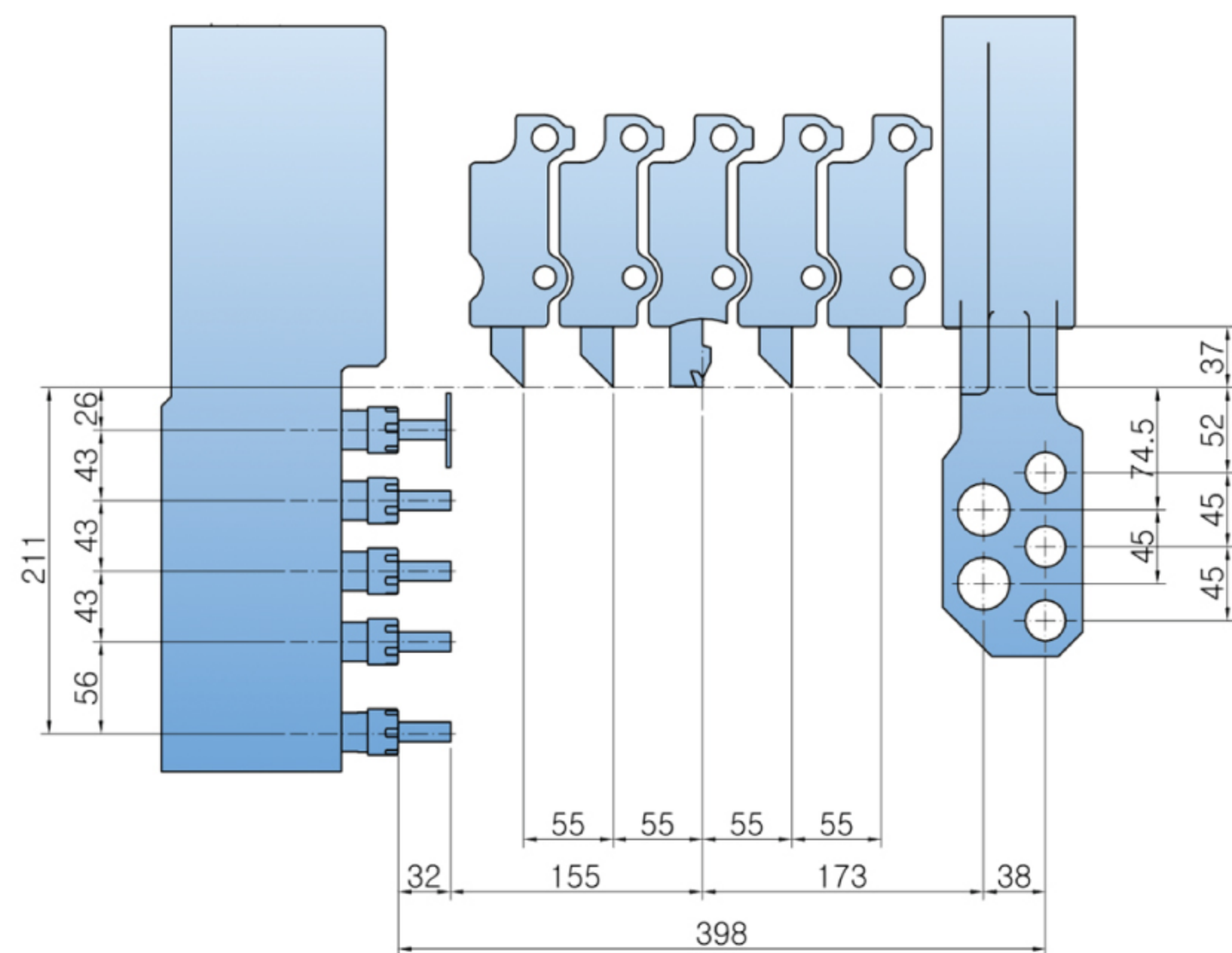

K2 type  
Hydraulic feed axis added

### \$1 (Main)

Tool name	Size	Equipment
O.D. Tool	□20 x 5	Standard
I.D. Tool	ER20 x 2 + ER16 x 3	Standard
Cross Drill	ER20 x 5	Standard
Long Drill	ER16 x 2	Standard

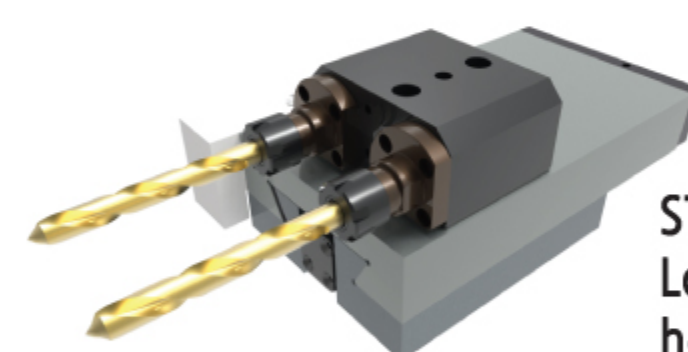

STANDARD  
Long drill For deep hole machining

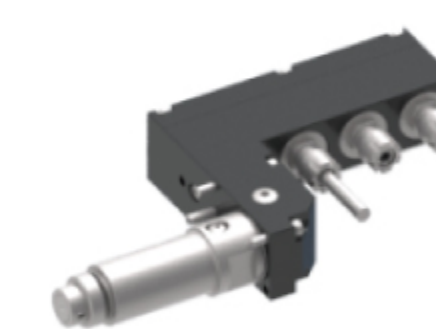

3-spindle drilling unit  
(E3 unit - Option)  
for eccentric machining

### \$2 (Sub)

Tool name	K2 Type (STD)
I.D. Tool	ER16 x 1
	ER20 x 2
I.D. Rotary Tool	ER20 x 3

## NN-38UB8 Specifications

Content	Specification	Specification Value	Standard Accessories
Machining capacity	Max. machining diameter	Φ38mm	I.D. tool unit
	Max. machining length	260mm / 1chuck	Cross drill unit
	Max. parts unloading length	115mm	Manual pulse generator(MPG)37P
Spindle	Main spindle through-hole diameter	Φ43mm	Coolant unit
	Spindle rpm (Main/Sub)	Max. 8,000rpm	Rotary guide bush
	Sub spindle chucking diameter	Φ38mm	Tool holder
Tool	Max. number of tools	30	Drill holder
	Max. machining drill	Φ13mm	Main : Chuck sleeve /Spring/Spindle cap(1set)
	Max. machining tap	M12	Sub : Chuck sleeve /Spring/Spindle cap(1set)
Main	O.D. tool	5 (□20X150mm max)	Automatic power turn-off device
	I.D. tool	5 (ER16X3 + ER20X2)	Automatic oiling device (level detector attached)
	Cross drill	5 (ER20)	Cuttign oil device (Main/Sub)
	Cross drill rpm	Max. 6,000rpm	Coolant failure detector
	Long drill	2EA (Φ13)	Overload detection function
SUB	I.D. tool	3 (ER20X2 + ER16X1)	Door interlock switch
	I.D. eccentric	3 (ER20)	Working light (LED)
	Cross drill	-	Parts conveyor
	I.D. drill rpm	Max. 6,000rpm	Parts catcher
Feed	Rapid feed rate	X1, X2, Y1 : 30/min Z1, Z2, : 28m/min	Levelling pad
	Min. command unit	0.0001mm	Signal warning light - 3 stage
	C axis Min. command unit (Main, Sub)	0.0001°	Display language (CHN/ENG/FRA/GER/ITA/JPN/KOR/POL/RUS/SPA)
Motor	Main spindle motor	7.5/5.5kW	Long drill holder
	Cross drill motor	1.5kW	Chip conveyor & Chip box
	Sub spindle motor	5.5/3.7kW	<b>Optional Accessories</b>
	\$2 cross drill motor	0.9kW	E3 UNIT
	Y1,Z1,X2.Z2 axis feed motor	0.5kW / 1.4kW	Fixed guide bush
	X1,Y2 axis feed motor	1.0kW / 1.4kW	Tap breakage detector (Main, Sub)
	Coolant pump (Main, Sub)	0.9kW + 0.25kW	Tool presetter
	Lubricant pump	0.003kW	Tool air blow
Dimensions and etc.	Main spindle center height	1,160mm	Rear ejection unit (Φ36mm or less)
	Input power capacity	40KVA	Spindle tube liner for small part
	Air pressure, flow rate	0.6MPa.25L/min	Large-sized lubricant pump 1.8ℓ
	Coolant tank	350L(Additioanl tank included)	Medium / High pressure coolant
	WxDxH	2,660x1,528x2,038 mm	Automatic fire extinguisher
	Weight (Options included)	3,600kg	Oil mist collector
NC	NC MITSUBISHI	M80	Custom colors
	NC display	10.4 Color TFT LCD	Tooling
	Memory capacity	500KB	
	Number of tool offset	256sets	
	Background edit function		
	C axis function (Main, Sub spindle)		
	User macro function		
	Nose R compensation		
	Corner chamfering /Corner rounding		
	Fixed cycle		
	Complex fixed cycle		
	Geometric commands		
	Controller manual		
	Serial in / Output interface		
CF card / USB interface			

### FLOOR Layout

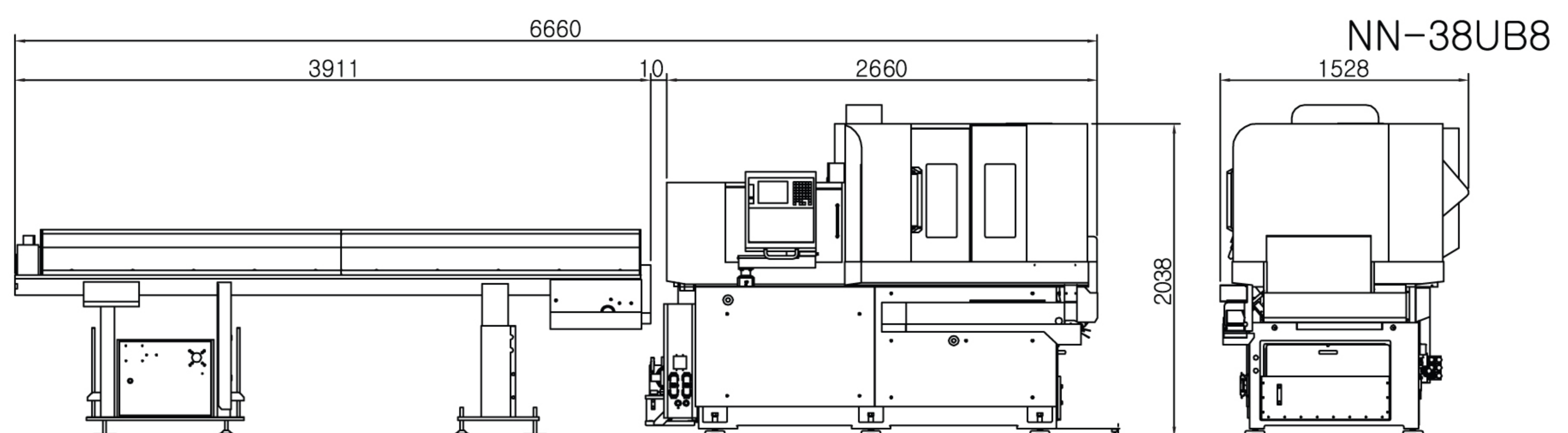



## DAESUNG HI-TECH CO.,LTD

10, Techno-daero 2-gil, Hyeonpung-myeon, Dalseong-gun, Daegu 43020, Korea

Tel +82-53-608-3662 Fax +82-53-592-6577

URL [www.topdsht.com](http://www.topdsht.com)

E-mail [info@topdsht.com](mailto:info@topdsht.com)



## NOMURADS CO.,LTD

3-1-12, IMAI, OME-CITY, TOKYO

198-0023, JAPAN

Tel +81-428-30-1313

Fax +81-428-30-1323

URL [www.nomurads.com](http://www.nomurads.com)

E-mail [dsht@topdsht.com](mailto:dsht@topdsht.com)

[sales1@topdsht.com](mailto:sales1@topdsht.com)



## DAESUNG HI-TECH VINA

TS9 Street, Tien Son Industrial Zone,  
Tuong Giang Commune, Tu Son Town,  
Bac Ninh Province

Tel +84-241-3734-4125~6

Fax +84-241-3734-4124

E-mail [hb.kim@topdsht.com](mailto:hb.kim@topdsht.com)

[hbkim90@gmail.com](mailto:hbkim90@gmail.com)



## Hanzung Numerical control CO., LTD

Xuling Village, Xinhua Street, Zhuanghe city,  
Dalian Liaoning Province, China ( Xinhua Industrial Zone)

Tel +86-411-89812963

Fax +86-411-89812962



## German office

Ludwig-Erhard-Str. 30-34,  
65760 Eschborn, Germany

Tel +49-6196-969-5646

URL [www.nomurads.de](http://www.nomurads.de)

E-mail [info@nomurads.de](mailto:info@nomurads.de)



Specifications may be subject to change without prior notice  
(for the purpose of quality improvement and function)

V707 P7718 WD